

**CITRUS
HEIGHTS
WATER
DISTRICT**

6230 Sylvan Road
P.O. Box 286
Citrus Heights
California
95611-0286

phone
916/ 725-6873
fax
916/ 725-0345
website
www.chwd.org

Board of Directors
Allen B. Dains
Caryl F. Sheehan
Raymond A. Riehle

*General Manager/
Secretary*
Robert A. Churchill

*Assistant General
Manager/Treasurer*
Hilary M. Straus

*Accounting Supervisor
Assessor/Collector*
Susan K. Sohal

**BOARD MEETING AGENDA
REGULAR MEETING OF THE BOARD OF DIRECTORS OF
CITRUS HEIGHTS WATER DISTRICT
MAY 10, 2016 beginning at 6:30 PM**

**DISTRICT ADMINISTRATIVE OFFICE
6230 SYLVAN ROAD, CITRUS HEIGHTS, CA**

In compliance with the Americans with Disabilities Act, if you have a disability and need a disability-related modification or accommodation to participate in this meeting, please contact the Assistant General Manager or Management Services Supervisor/Chief Board Clerk at (916) 725-6873. Requests must be made as early as possible, and at least one full business day before the start of the meeting.

CALL TO ORDER:

Upon request, agenda items may be moved to accommodate those in attendance wishing to address that item. Please inform the General Manager.

ROLL CALL OF DIRECTORS:

PLEDGE OF ALLEGIENCE:

VISITORS:

Students, Teachers and Families of Water Awareness Poster Contest
Winners
Jim Crowley, The Crowley Group, Inc.
David Alvey, Maze & Associates
Cody Smith, Maze & Associates

PUBLIC COMMENT:

The Public shall have the opportunity to directly address the Board on any item of interest to the public before or during the Board's consideration of that item pursuant to Government Code Section 54954.3. Public comment on items of interest within the jurisdiction of the Board is welcome. The Presiding Officer will limit comments to three (3) minutes per speaker.

(A) Action Item (D) Discussion Item (I) Information Item

CONSENT CALENDAR: (A)

All items under the Consent Calendar are considered to be routine and will be approved by one motion. There will be no separate discussion of these items unless a member of the Board, Audience, or Staff request a specific item be removed for separate discussion/action before the motion to approve the Consent Calendar.

- CC-1 Minutes of the Regular Meeting – April 12, 2016.
- CC-1a. Minutes of the Special Meeting – April 18, 2016.
- CC-2. Revenue Analysis Report for April 2016.
- CC-3. Assessor/Collector's Roll Adjustment for April 2016.
- CC-4. Treasurer's Report for April 2016.
- CC-5. Treasurer's Report of Fund Balances for April 2016.
- CC-6. Operations Budget Analysis for April 2016.
- CC-7. Capital Improvements Budget Analysis for April 2016.

- CC-8. Payables for April 2016.
- CC-9. CAL-Card Purchases for April 2016.
- CC-10. Summary of 2016 Directors, Officers and Employees Training, Seminars and Conference Expenses.

CC-11. Administration Building Improvements Project (I)
Receive information on adding an office to the Administration Building.

CC-12. Authorization for Accounting Supervisor to Attend Government Finance Officers Association (GFOA) Annual Conference (A)
Consider authorizing Accounting Supervisor to attend GFOA Conference and authorizing the General Manager to approve actual and necessary expense reimbursements related to conference attendance.

CC-13. Claim for Damages (A)
Consider a claim for property damage from Salvador Ramirez.

PRESENTATIONS:

- P-1. Water Awareness Poster Contest
Present awards to the winners of this year's Water Conservation Poster Contest conducted by CHWD and the San Juan Family of Agencies.

- P-2. Preparation of the 2015 Urban Water Management Plan (D/A)
 - a. Present for review, discussion and comments the DRAFT 2015 Urban Water Management Plan (UWMP) being presented by the J. Crowley Group, Inc.
 - b. Call of a Public Hearing on June 14, 2016 to consider adoption of the UMWP.

PUBLIC HEARING:

- PH-1. Adoption of Water Conservation Ordinance 01-2016 (A)
Conduct a Public Hearing and consider Adoption of Ordinance 01-2016 restating and reauthorizing the establishment of a Water Conservation Program, Mandatory Water Conservation Stage Regulations and progressive Enforcement Measures.

OLD BUSINESS:

- O-1. Skycrest Well Equipping Project (A)
Consider Adoption of Resolution 09-2016 Accepting the Skycrest Well Equipping Project (2013-21), and authorize execution and recording of a Notice of Completion for the Project.

- O-2. San Juan Park 12-Inch Transmission Main and 8-Inch Distribution Main Installation Project (A)
Consider Adoption of Resolution 10-2016 Accepting the San Juan Park 12-Inch Transmission Main and 8-Inch Distribution Main Installation Project (2014-36), and

authorize execution and recording of a Notice of Completion for the Project.

NEW BUSINESS:

- N-1. Training/Continued Education /Meetings (I)
Discuss training, continued education, and meeting opportunities.
- N-2. Auction of Surplus Equipment (A)
Consider sale of equipment that is surplus to the needs of the District by selling it at public auction.
- N-3. Test Hole Bids (A)
Consider acceptance of bids to drill and abandon test holes in the District Service Area.
- N-4. Financial Audit Report (A)
Receive a report from Maze and Associates, CPA, regarding the District's Financial Audit for 2015; and consider acceptance of the District's financial records for 2015.
- N-5. Strategic Planning (A)
Consider Dates to schedule the Strategic Planning Session.
- N-6. Election Services MOU with Sacramento County (A)
Consider approval of a Memorandum of Understanding with Sacramento County for Election Services and Authorize execution by the General Manager.
- N-7. November 2016 General Election (A)
Adopt Resolutions 11-2016 (Sacramento County) and 12-2016 (Placer County) calling for a November 8, 2016 election of a Director for a regular 4-year term in Division One and election of a Director for a short 2-year term in Division Two.
- N-8. "At-Will" Employment—Employment Agreements for Managers and Direct Reports to the General Manager (A)
Consider adopting employment agreement template and accompanying policy changes that will apply only to employees under employment agreements. Authorize the General Manager to utilize the employment template for employment agreements with direct reports.

CONSULTANTS' AND LEGAL COUNSEL'S REPORTS (I):

PROJECT MANAGER'S REPORTS (I):

- PM-1. Accepted Water Systems.
- PM-2. Projects Under Construction by Private Developers.
- PM-3. Contractor / Developer Projects Pending Construction.
- PM-4. Proposed District Capital Improvement Projects.
- PM-5. Projects Contracted by Citrus Heights Water District.

PM-6. City of Citrus Heights Projects.

OPERATIONS MANAGER'S REPORTS (I):

OM-1. Monthly report on construction and maintenance activities plus water analysis reports.

OM-2. 2016 Water Consumption.

OM-3. Surface Water Supply.

RECESS: The Meeting will have a brief recess.

DIRECTOR'S AND REPRESENTATIVE'S REPORTS (I):

D-1. Regional Water Authority (Dains, Churchill).

D-2. Sacramento Groundwater Authority (Sheehan).

D-3. San Juan Water District.

D-4. Association of California Water Agencies (Dains).

a. ACWA 2016 Spring Conference (Dains)

D-5. ACWA Joint Powers Insurance Authority.

D-6. Sacramento Local Agency Formation Commission.

D-7. City of Citrus Heights.

D-8. Chamber of Commerce Government Issues Committee (Straus).

D-9. Other Reports:

ASSISTANT GENERAL MANAGER'S REPORTS (I):

AGM-1. Water Efficiency Program Update.

AGM-2. Drought Response Plan Update.

AGM-3. Paladin Night Patrol Update.

AGM-4. ACWA 2016 Spring Conference.

GENERAL MANAGER'S REPORTS (I):

GM-1. Employee Recognition.

GM-2. General Manager's Task List.

GM-3. Long Range Board Agenda.

GM-4. Operations Manager Appointment.

GM-5. ACWA 2016 Spring Conference.

CORRESPONDENCE:

None

CLOSED SESSION:

CL-1. Public Employee Retirement and Succession - discussion under Personnel Exemption (California Government Code Section 54957) (D)

OPEN SESSION:

Report from Closed Session

FUTURE CHWD BOARD OF DIRECTORS MEETING DATES:

June 14, 2016 6:30 PM Regular Meeting

July 12, 2016 6:30 PM Regular Meeting

ADJOURNMENT:

CERTIFICATION:

I do hereby declare and certify that this agenda for this Regular Meeting of the Board of Directors of the Citrus Heights Water District was posted in a location accessible to the public at the District Administrative Office Building, 6230 Sylvan Road, Citrus Heights, CA 95610 at least 72 hours prior to the regular meeting in accordance with Government Code Section 54954.2.

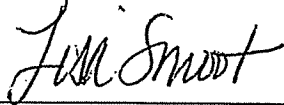

LISA A. SMOOT, Chief Board Clerk

Dated: May 5, 2016

CITRUS HEIGHTS WATER DISTRICT
BOARD OF DIRECTORS REGULAR MEETING
April 12, 2016

The Regular Meeting of the Board of Directors was called to order at 6:31 p.m. by President Dains and roll was called. Present were:

Allen B. Dains, President
Caryl F. Sheehan, Director
Raymond A. Riehle, Director
Robert A. Churchill, General Manager
Hilary M. Straus, Assistant General Manager
David M. Gordon, Interim Operations Manager
Paul A. Dietrich, Project Manager
Lisa A. Smoot, Human Resources Specialist
Mellie D. Deano, Temporary Accounting Staff

VISITORS

Beth Shockley, District Employee
Nick Spiers, District Employee
Rex Meurer, District Employee

PLEDGE OF ALLEGIANCE

Director Dains led the Pledge of Allegiance.

PUBLIC COMMENT

There was no Public Comment.

CONSENT CALENDAR

President Dains asked for consideration and/or approval of the Consent Calendar.

Motion: It was moved by Director Riehle and seconded by Director Sheehan to accept the Consent Calendar, consisting of:

- CC-1 Minutes of the Regular Meeting – March 8, 2016.
- CC-1a. Minutes of the Special Meeting – March 24, 2016.
- CC-1b. Minutes of the Special Meeting – March 28, 2016.
- CC-2. Revenue Analysis Report for March 2016.
- CC-3. Assessor/Collector's Roll Adjustment for March 2016.
- CC-4. Treasurer's Report for March 2016.
- CC-5. Treasurer's Report of Fund Balances for March 2016.
- CC-6. Operations Budget Analysis for March 2016.
- CC-7. Capital Improvements Budget Analysis for March 2016.
- CC-8. Payables for March 2016.

- CC-9. CAL–Card Purchases for March 2016.
- CC-10. Summary of 2016 Directors, Officers and Employees Training, Seminars and Conference Expenses.
- CC-11. San Juan High School Easement (A)
Adoption of Resolution 07-2016 accepting an easement at San Juan High School.
- CC-12. Administration Building Improvements Project (I)
Receive information on adding an additional office to the Administration Building.
- CC-13. Skycrest Well Equipping Project (I)
Receive a status report on the Project.

MARCH 31, 2016 PAYABLES

| Check # | Vendor | Description | Amount |
|---------|---|---------------------------------|-------------|
| 60836 | James G. Ferro | Continued Education | \$97.58 |
| 60837 | Ryon Ridner | Continued Education | \$1,850.64 |
| 60838 | The Lincoln National Life Insurance Company | Disability & Life Insurance | \$5,912.15 |
| 60839 | Robin Cope | Health Insurance | \$402.00 |
| 60840 | City of Citrus Heights | Permit Fees | \$1,500.00 |
| 60841 | Sacramento Metro Fire District | Permit Fees | \$521.00 |
| 60842 | Petty Cash | Petty Cash | \$146.80 |
| 60843 | Paul N Phillips, Attorney at Law | Legal & Audit | \$3,937.50 |
| 61156 | CalSierra Construction Inc | Contract Services-Engineering | \$29,317.00 |
| 61157 | Lamon Construction CO, INC | Contract Services-Engineering | \$78,001.87 |
| 61158 | Ernest L Leporini | Contract Services-Engineering | \$10,680.00 |
| 61159 | Pace Supply Corp | Material | \$16,601.00 |
| 61160 | Void- Printer Error | Void | \$0.00 |
| 61161 | Void- Printer Error | Void | \$0.00 |
| 61162 | Void- Printer Error | Void | \$0.00 |
| 61163 | R E Smith Contractor Inc | Contract Services-Wells | \$44,420.96 |
| 61164 | Azteca Systems Inc | Maintenances Agreement-Software | \$19,995.00 |
| 61165 | SMUD | Utilities | \$11,779.67 |
| 61166 | US Bank I.M.P.A.C. Government Services | See March Agenda Item CC:9 | \$8,852.63 |
| 61167 | Kathleen C Duncan | Customer Refund | \$107.44 |
| 61168 | Mitchell D Lopez | Customer Refund | \$13.47 |
| 61169 | Martin Brothers Construction, Inc. | Customer Refund | \$1,399.31 |
| 61170 | James P/Megan Kiernan | Customer Refund | \$165.57 |
| 61171 | Robert/Maria L Sharon | Customer Refund | \$17.83 |
| 61172 | Latha Reghunathan | Customer Refund | \$23.54 |
| 61173 | Watt Communities at Autumnwood | Customer Refund | \$61.22 |
| 61174 | Absolute Secured Shredding Inc | Equipment Rental- Office | \$45.00 |
| 61175 | Alexander's Contract Services | Contract Services-Meter Reads | \$2,389.18 |

| | | | |
|-------|---|-----------------------------------|------------|
| 61176 | AREA Restroom Solutions | Equipment Rental-Field | \$114.34 |
| 61177 | BSK Associates | Water Analysis | \$228.00 |
| 61178 | California Urban Water Conservation Council | Water Conservation-Other | \$3,273.52 |
| 61179 | Coverall North America Inc | Janitorial | \$450.00 |
| 61180 | Cybex | Equipment Rental- Office | \$129.12 |
| 61181 | Integrity Administrators Inc | Health Insurance | \$299.75 |
| 61182 | KASL Consulting Engineers | Contract Services-Engineering | \$5,479.00 |
| 61183 | Kei Window Cleaning #12 | Janitorial | \$92.00 |
| 61184 | Douglas A MacTaggart | Contract Services-Concrete | \$3,814.00 |
| 61185 | Moonlight BPO | Contract Services-Bill Print | \$978.03 |
| 61186 | Paul N Phillips, Attorney at Law | Legal & Audit | \$1,500.00 |
| 61187 | Powerplan | Repair-Trucks | \$295.31 |
| 61188 | Sonitrol | Equipment Rental- Office | \$156.23 |
| 61189 | SWRCB | Dues & Subscriptions | \$55.00 |
| 61190 | The Lincoln National Life Insurance Company | Disability & Life Insurance | \$5,701.13 |
| 61191 | Titan Workforce LLC | Contract Services-Temporary Labor | \$6,002.63 |
| 61192 | Trench Plate Rental Co | Equipment Rental-Field | \$3,565.16 |
| 61193 | Bales Family Trust | Customer Refund | \$5.80 |
| 61194 | Chino S/Tina T Lee | Customer Refund | \$57.30 |
| 61195 | Crosby Trust/Charles Crosby Jr | Customer Refund | \$166.14 |
| 61196 | Gerilee D Pope | Customer Refund | \$157.66 |
| 61197 | Jeffrey C/Judy Leonetti | Customer Refund | \$167.69 |
| 61198 | Jana E Maddux | Customer Refund | \$34.22 |
| 61199 | Peters Family Trust | Customer Refund | \$109.82 |
| 61200 | Sharon A Panning | Customer Refund | \$10.42 |
| 61201 | Mildred A Chaffin | Customer Refund | \$6.13 |
| 61202 | Kelly Trust | Customer Refund | \$108.30 |
| 61203 | Steven/Teresa Barry | Customer Refund | \$24.99 |
| 61204 | Merlyn/Nancy T Lund | Customer Refund | \$38.86 |
| 61205 | Suzanne Meade | Customer Refund | \$23.32 |
| 61206 | Hal/Susan L Faresh | Customer Refund | \$38.54 |
| 61207 | Teddy H Wilson | Customer Refund | \$14.27 |
| 61208 | Sentinel Field Services | Customer Refund | \$171.41 |
| 61209 | Brittany R/Christopher R Wilson | Customer Refund | \$66.21 |
| 61210 | Marina/Luke Michael Williams | Customer Refund | \$9.00 |
| 61211 | Capital Ventures Group LLC | Customer Refund | \$13.94 |
| 61212 | Cal Sierra Construction, Inc. | Customer Refund | \$1,750.00 |
| 61213 | Primo Farms LLC | Customer Refund | \$41.76 |
| 61214 | Multigroup LLC | Customer Refund | \$19.14 |
| 61215 | Tracey Langley | Customer Refund | \$121.99 |
| 61216 | ACWA/JPIA | Workers Comp Insurance | \$7,453.00 |
| 61217 | AFLAC | Employee Paid Insurance | \$375.06 |
| 61218 | Alexander's Contract Services | Contract Services-Meter Reads | \$3,891.02 |
| 61219 | AnswerNet | Telephone-Answering Service | \$150.53 |
| 61220 | Automate Mailing | Contract Services-Bill Print | \$7,526.84 |

| | | | |
|-------|--|--------------------------------------|------------|
| 61221 | BSK Associates | Water Analysis | \$480.00 |
| 61222 | Burketts | Office Expense | \$125.34 |
| 61223 | California Landscape Associates Inc | Janitorial | \$187.00 |
| 61224 | California Surveying & Drafting Supply | Small Tools | \$5.00 |
| 61225 | Caltronics Business System | Small Office Equipment | \$362.02 |
| 61226 | Corix Water Products, Inc | Material | \$6,680.99 |
| 61227 | J Crowley Group Inc | Water Conservation-Other | \$5,940.00 |
| 61228 | Dawson Oil Company | Gas & Oil | \$1,024.46 |
| 61229 | Grainger | Small Tools | \$807.84 |
| 61230 | J4 Systems | Contract Services-Other | \$3,545.00 |
| 61231 | KBA DOCUSYS | Maintenance Agreement-Equipment | \$18.84 |
| 61232 | KBA Docusys Inc | Equipment Rental- Office | \$343.43 |
| 61233 | L and D Landfill | Contract Services-Miscellaneous | \$811.68 |
| 61234 | Liebert Cassidy Whitmore | Legal & Audit | \$32.50 |
| 61235 | Moonlight BPO | Contract Services-Bill Print | \$4,522.61 |
| 61236 | Office Depot | Office Expense | \$100.74 |
| 61237 | Void | Void | \$0.00 |
| 61238 | Republic Services #922 | Utilities | \$196.07 |
| 61239 | RW Trucking | Contract Services-Miscellaneous | \$3,515.00 |
| 61240 | Regional Water Authority | Dues & Subscriptions | \$142.84 |
| 61241 | SMAQMD | Permit Fees | \$2,034.00 |
| 61242 | Sierra Office and Printing | Water Conservation-Material/Supplies | \$2,429.00 |
| 61243 | SureWest Directories | Telephone-Local/Long Distance | \$49.00 |
| 61244 | Zane Dezn | Contract Services-Water Conservation | \$420.13 |
| 61245 | Void | Void | \$0.00 |
| 61246 | Protection One Alarm Monitoring | Equipment Rental- Office | \$140.00 |
| 61247 | Powerplan | Repair-Trucks | \$166.69 |
| 61248 | Stanley/Linda Ruggles Jr | Customer Refund | \$98.41 |
| 61249 | David Brown/Paul E Brown/Darlene L Brown | Customer Refund | \$91.42 |
| 61250 | Yuri/Inna Kulinich | Customer Refund | \$14.89 |
| 61251 | Gloria Lomascola | Customer Refund | \$136.48 |
| 61252 | David/Alethal Kehler | Customer Refund | \$284.11 |
| 61253 | Toby C Mitchell | Customer Refund | \$18.81 |
| 61254 | Rachel Atkinson | Customer Refund | \$183.96 |
| 61255 | John R Sunzeri Jr | Customer Refund | \$75.27 |
| 61256 | Alton E Hardin Jr | Customer Refund | \$15.04 |
| 61257 | David B/Vivian C Janzen | Customer Refund | \$8.41 |
| 61258 | John/Sherri Godschalk | Customer Refund | \$33.23 |
| 61259 | MST Holdings LLC | Customer Refund | \$24.72 |
| 61260 | Airgas NCN | Supplies-Field | \$128.53 |
| 61261 | Alexander's Contract Services | Contract Services-Meter Reads | \$2,638.27 |
| 61262 | All American Publishing | Water Conservation-Other | \$374.00 |
| 61263 | Bart/Riebes Auto Parts | Repair-Trucks | \$251.35 |
| 61264 | Bryce Consulting, Inc | Legal & Audit | \$5,840.00 |
| 61265 | California Surveying & Drafting Supply | Small Tools | \$5.00 |

| | | | |
|-------|---|--------------------------------------|-------------|
| 61266 | CirclePoint | Contract Services-Water Conservation | \$5,033.75 |
| 61267 | City of Citrus Heights | Permit Fees | \$1,400.00 |
| 61268 | Corelogic Information Solutions Inc | Dues & Subscriptions | \$246.83 |
| 61269 | Corix Water Products, Inc | Material | \$7,802.42 |
| 61270 | County of Sacramento - Clerk | Publication Notices | \$80.00 |
| 61271 | Michael Dunn | Water Conservation-Rebates | \$640.00 |
| 61272 | Indoor Environmental Services | Maintenance Agreement-Equipment | \$130.00 |
| 61273 | Integrity Administrators Inc | Health Insurance | \$5,000.00 |
| 61274 | J4 Systems | Contract Services-Other | \$280.00 |
| 61275 | Kaiser Foundation Health Plan, Inc | Health Insurance | \$14,287.76 |
| 61276 | Moonlight BPO | Contract Services-Bill Print | \$2,412.88 |
| 61277 | Pace Supply Corp | Material | \$217.99 |
| 61278 | Pacific Gas & Electric | Utilities | \$42.93 |
| 61279 | Pollardwater.com - East | Small Tools | \$917.18 |
| 61280 | Red Wing Shoe Store | Small Tools | \$460.00 |
| 61281 | SHI International Corp | Maintenances Agreement-Software | \$3,638.52 |
| 61282 | Sophos Solutions | Contract Services-Other | \$5,920.00 |
| 61283 | Sunstate Equipment Co | Equipment Rental-Field | \$513.85 |
| 61284 | A. Teichert & Son, Inc. | Road Base | \$1,736.74 |
| 61285 | The Lincoln National Life Insurance Company | Disability & Life Insurance | \$5,771.47 |
| 61286 | Titan Workforce LLC | Contract Services-Temporary Labor | \$7,585.25 |
| 61287 | Voyager Fleet Systems Inc | Gas & Oil | \$1,179.92 |
| 61288 | WaterWise Consulting, Inc | Contract Services-Water Conservation | \$1,625.00 |
| 61289 | City of Citrus Heights | Permit Fees | \$486.38 |
| 61290 | Ben or Bonnie Bellotti | Toilet Rebate Program | \$75.00 |
| 61291 | Donald W or Lynda M Bridges | Toilet Rebate Program | \$75.00 |
| 61292 | Jon L or Lana C Dresser | Toilet Rebate Program | \$150.00 |
| 61293 | Kenneth R Fox or Sue Fairbanks | Toilet Rebate Program | \$75.00 |
| 61294 | Lee N or Jamie L Kirtley | Toilet Rebate Program | \$150.00 |
| 61295 | Louis P Lyon | Toilet Rebate Program | \$150.00 |
| 61296 | Cynthia Masterson | Toilet Rebate Program | \$150.00 |
| 61297 | Jeremy or Anna Maurer | Toilet Rebate Program | \$75.00 |
| 61298 | Linda C Schoephoerster | Customer Refund | \$165.19 |
| 61299 | Lamon Construction | Customer Refund | \$1,493.49 |
| 61300 | ABA DABA Rentals & Sales | Supplies-Field | \$110.93 |
| 61301 | Alexander's Contract Services | Contract Services-Meter Reads | \$2,457.49 |
| 61302 | AREA Restroom Solutions | Equipment Rental-Field | \$114.34 |
| 61303 | Auburn Dam Council | Dues & Subscriptions | \$100.00 |
| 61304 | BSK Associates | Water Analysis | \$1,522.00 |
| 61305 | California Surveying & Drafting Supply | Small Tools | \$5.00 |
| 61306 | Dawson Oil Company | Gas & Oil | \$737.03 |
| 61307 | Demsey, Filliger & Associates LLC | Legal & Audit | \$3,000.00 |
| 61308 | Kelly R Drake | Printing | \$30.00 |
| 61309 | EH Wachs | Contract Services-Equipment/Hardware | \$2,879.76 |
| 61310 | James G. Ferro | Continued Education | \$38.29 |

| | | | |
|--------------|--|--------------------------------------|----------------------------|
| 61311 | Future Ford | Repair-Trucks | \$1,197.24 |
| 61312 | Global Machinery West | Fixed Assets | \$2,586.87 |
| 61313 | Ferguson Enterprises Inc #1423 | Material | \$674.84 |
| 61314 | Integrity Administrators Inc | Health Insurance | \$277.20 |
| 61315 | J&J Locksmiths | Contract Services-Other | \$943.03 |
| 61316 | J4 Systems | Contract Services-Other | \$420.00 |
| 61317 | KASL Consulting Engineers | Contract Services-Engineering | \$6,760.00 |
| 61318 | Kleinfelder | Contract Services-Miscellaneous | \$538.50 |
| 61319 | Ernest L Leporini | Contract Services-Engineering | \$4,740.00 |
| 61320 | Mike Mariedth | Continued Education | \$48.29 |
| 61321 | Rex Meurer | Water Conservation-Material/Supplies | \$112.00 |
| 61322 | Moonlight BPO | Contract Services-Bill Print | \$1,107.39 |
| 61323 | Office Depot | Office Expense | \$190.90 |
| 61324 | Pace Supply Corp | Material | \$1,522.40 |
| 61325 | Pacific Mechanical Services Inc | Contract Services-Other | \$315.00 |
| 61326 | Zachary Powell | Continued Education | \$98.29 |
| 61327 | Rescue Training Institute Inc | Fixed Assets | \$1,533.00 |
| 61328 | The Sacramento Gazette | Publication Notices | \$75.50 |
| 61329 | Les Schwab Tires | Repair-Trucks | \$802.61 |
| 61330 | SMUD | Utilities | \$1,395.57 |
| 61331 | A. Teichert & Son, Inc. | Road Base | \$1,022.22 |
| 61332 | Titan Workforce LLC | Contract Services-Temporary Labor | \$7,975.26 |
| 61333 | Trench Plate Rental Co | Equipment Rental-Field | \$2,205.20 |
| 61334 | US Bank I.M.P.A.C. Government Services | See March Agenda Item CC:9 | \$6,697.77 |
| 61335 | Verizon Wireless | Telephone-Wireless | \$1,104.51 |
| 61336 | Vice's Collision Repair | Repair-Trucks | \$3,995.80 |
| 61337 | World Environment & Energy Inc | Contract Services-Miscellaneous | \$375.00 |
| TOTAL | | | <u>\$466,903.80</u> |
| ACH | FEB2016 BOW | Bank Fee | \$2,282.93 |
| ACH | WHA APRIL2016 HEALTH | Health Insurance | \$15,805.94 |
| ACH | VALIC3/24/16 PAYDAY | Deferred Compensation | \$2,895.00 |
| ACH | PERS3/10/16 PAYROLL | PERS | \$12,870.29 |
| ACH | PERS 3/24/16PAYROLL | PERS | \$13,254.50 |
| ACH | WELLS FARGO MARCH2016 | COP Debt Service | \$50,502.68 |
| ACH | FEB2016FD | Bank Fee | \$214.00 |
| ACH | FEB2016PAYCHEX | Contract Services-Other | \$322.05 |
| ACH | FEB2016PH | Bank Fee | \$241.58 |
| ACH | FEB2016VANCO | Bank Fee | \$70.30 |
| ACH | FEB2016WB | Bank Fee | \$2,847.99 |
| ACH | VALIC3/10/16 | Deferred Compensation | \$2,895.00 |
| ACH | VK70773/10/16 | Deferred Compensation | \$45.00 |
| ACH | VK70773/24/16 | Deferred Compensation | \$45.00 |
| TOTAL | | | <u>\$104,292.26</u> |

GRAND TOTAL

\$571,196.06

April Checks Approved At April Board Meeting

| | | | |
|-------|--|-------------------------------|----------------------------|
| 61343 | Warren Consulting Engineers Inc | Contract Services-Engineering | \$8,635.00 |
| 61340 | Paladin Private Security | Water Conservation-Other | \$10,296.00 |
| 61345 | ACWA/JPIA | Workers Comp Insurance | \$10,338.00 |
| 61339 | Maze & Associates | Legal & Audit | \$11,648.00 |
| 61344 | Central Valley Engineering & Asphalt, Inc. | ContractServices-Other | \$12,045.55 |
| 61342 | SMUD | Utilities | \$13,471.12 |
| 61338 | Ferguson Enterprises Inc #1423 | Material | \$14,075.64 |
| 61341 | R E Smith Contractor Inc | Contract Services-Other | \$107,857.14 |
| | | | <u>\$188,366.45</u> |

**CITRUS HEIGHTS WATER DISTRICT
RESOLUTION NO. 07 -2016**

**RESOLUTION OF THE BOARD OF DIRECTORS
OF CITRUS HEIGHTS WATER DISTRICT
ACCEPTING AN EASEMENT FROM
SAN JUAN UNIFIED SCHOOL DISTRICT
FOR WATER DISTRIBUTION FACILITIES WITHIN
7551 GREENBACK LANE, SAN JUAN HIGH SCHOOL**

Whereas San Juan Unified School District for a valuable consideration, receipt of which is hereby acknowledged, does hereby grant to CITRUS HEIGHTS WATER DISTRICT, a political subdivision of the State of California formed pursuant to Division 11 of the Water Code, a right-of-way and easement to construct, reconstruct, operate, maintain and/or repair water pipelines together with any and all appurtenances appertaining thereto; together with the perpetual right of ingress thereto and egress there from for the purpose of exercising and performing all of the rights and privileges granted herein; said pipelines and appurtenances to be of such size(s) and character as the grantee may determine, on, over, across and under all that certain real property, situate in the City of Citrus Heights, County of Sacramento, State of California particularly described as follows:

All that certain real property located in the Northeast ¼ of Section 35, Township 10, North, Range 6 East, Mount Diablo Meridian, County of Sacramento, State of California and being a portion of Lot 3 and Lot 7 of Citrus Heights Addition Number 3 as Recorded in Book 12 of Maps at Page 2 on file at the County Recorder's Office, County of Sacramento, State of California and being described as follows:

Beginning at a point which bears the following four (4) courses from a found one-inch iron pipe at the centerline of the intersection of Mariposa Avenue and Heatherington Way as shown on the Map of Heatherington Estates as Recorded in Book 190 of Maps at Page 5 on file at said County Recorder's Office;

1. Along the centerline of Mariposa Avenue South 00°14'00" West 839.38 feet;

2. Leaving said centerline of Mariposa Avenue North 89°46'00" West 30.00 feet;
3. West 178.81 feet;
4. North 44°50'12" West 22.00 feet to the Point of Beginning.

Thence the following sixteen (16) courses:

1. South 45°09'48" West 15.00 feet;
2. North 44°53'28" West 144.45 feet;
3. West 249.83 feet;
4. North 43°12'45" West 71.81 feet;
5. West 479.29 feet;
6. North 64°40'35" West 52.66 feet to the easterly line of that certain parcel of land Recorded in Document Number 1004051196, on file at the County Recorder's Office, County of Sacramento, State of California;
7. Along said easterly line North 00°14'00" East 16.56 feet;
8. Leaving said easterly line South 64°40'35" East 56.31 feet;
9. East 377.16 feet;
10. North 10.46 feet;
11. East 5.00 feet;
12. South 10.46 feet;
13. East 100.26 feet;
14. South 43°12'45" East 71.81 feet;
15. East 249.57 feet;
16. South 44°53'28" East 150.69 to the Point of Beginning.
Containing 15,118.75 square feet or 0.347 acres+/-

Basis of Bearing for this description is identical to that certain Map of Citrus Heights Addition Number 3 as Recorded in Book 12 of Maps at Page 2 of file at the County Recorder's Office, County of Sacramento, State of California.

NOW THEREFORE, BE IT RESOLVED that CITRUS HEIGHTS WATER DISTRICT accepts said Grant of Easement and conveyance and that a certified copy of this Resolution be provided to the County of Sacramento to be attached to and recorded with said Grant of Easement in the Office of the County Recorder of Sacramento County.

PASSED AND ADOPTED by the Board of Directors of the CITRUS HEIGHTS WATER DISTRICT this 12th day of April 2016 by the following vote, to wit:

AYES: Directors: Dains, Sheehan, Riehle
NOES: Directors:
ABSTAIN: Directors:
ABSENT: Directors:

SEAL

ALLEN B. DAINS, President
Board of Directors
Citrus Heights Water District

ATTEST:

ROBERT A. CHURCHILL, Secretary
Citrus Heights Water District

The motion carried 3-0 with all Directors voting yes.

OLD BUSINESS:

San Juan High School 24-Inch Transmission Main Installation Project (A)

Consider Adoption of Resolution 08-2016 Accepting the San Juan High School 24-Inch Transmission Main Installation Project (2013-30), and authorize execution and recording of a Notice of Completion for the Project.

CITRUS HEIGHTS WATER DISTRICT
RESOLUTION NO. 08-2016

RESOLUTION OF THE BOARD OF DIRECTORS
ACCEPTING

THE SAN JUAN HIGH SCHOOL 24-INCH TRANSMISSION MAIN INSTALLATION PROJECT

WHEREAS, on August 11, 2015 the Board of Directors of the Citrus Heights Water District authorized the award of a contract to Lamson Construction Company, Inc. for the San Juan High School 24-Inch Transmission Main Installation Project; and

WHEREAS, on September 2, 2015 the contract was fully executed between the District and Lamson Construction Company, Inc.; and

WHEREAS, Lamson Construction Company, Inc. has completed the work for the San Juan High School 24-Inch Transmission Main Installation Project in accordance with the plans, specifications and contract documents prepared by the District pursuant to a final inspection on March 3, 2016.

NOW, THEREFORE, BE IT RESOLVED by the Board of Directors of Citrus Heights Water District that the San Juan High School 24-Inch Transmission Main Installation Project is accepted as complete.

BE IT FURTHER RESOLVED that the District Secretary is authorized to execute a Notice of Completion for the San Juan High School 24-Inch Transmission Main Installation Project and to have said Notice recorded with the Office of the Recorder of Sacramento County.

PASSED AND ADOPTED by the Board of Directors of the CITRUS HEIGHTS WATER DISTRICT this 12th day of April 2016 by the following vote, to wit:

AYES: Directors: Dains, Sheehan, Riehle
NOES: Directors:

ABSTAIN: Directors:
ABSENT: Directors:

SEAL

ALLEN B. DAINS, President
Board of Directors
Citrus Heights Water District

ATTEST:

ROBERT A. CHURCHILL, Secretary
Citrus Heights Water District

ACTION: Director Riehle moved and Director Sheehan seconded the motion to: Adopt Resolution 08-2016 Accepting the San Juan High School 24-inch Transmission Main Installation Project (2013-30), and authorize the District Secretary to execute and record Notice of Completion for the Project.

The motion carried 3-0 with all Directors voting yes.

Administration Building Improvements Project (I)

As reported at the February 9, 2016 Board of Directors Meeting , a task order was approved with Blackbird Associates to proceed with the design work of enclosing the 160 square foot patio area between the General Manager and Accounting Supervisor offices. A change order in the amount of \$ 55,225.00 authorizing Kaler/Dobler to proceed with construction has been executed.

Approval has been received from Sacramento Metro Fire District and an Exempt Certificate of Compliance has been obtained from the San Juan Unified School District. Issuance of a building permit from the City of Citrus Heights is expected any day.

The target date for completion is June 15, 2016.

Skycrest Well Equipping Project (I)

At the January 13, 2015 Board Meeting the Board accepted the bid of R.E. Smith Contractor, Inc. in the amount of \$1,822,000.00 and established a change order contingency fund in the amount of \$90,000.00 (4.94%) for equipping the Skycrest Well. This work includes the pump, motor, building, electrical and mechanical components, water and storm drain piping, fencing and other site improvements.

An Agreement for Construction Services between the District and R.E. Smith Contractor, Inc. was executed on February 23, 2015. Completion date TBD, contingent on weather.

On February 29, 2016 a check in the amount of \$540,000.00 from the California Department of Water Resources' (DWR) Proposition 50 Grant awarded to RWA on behalf of Citrus

Heights Water District (CHWD) was received, with 10 percent retention withheld until the project is complete.

Fencing and gates have been completed. Notice of Completion will be issued and final retention payment will be made when final punch-list items are completed. Department of Drinking Water data review and Permit Amendment are in process.

NEW BUSINESS:

Training/Continued Education/Meetings

ACWA-JPIA Spring Conference, Monterey, May 2-6 – Director Dains, GM Churchill and AGM Straus will attend.

On-Call Pavement Restoration Bids (A)

Consider acceptance of a bid to install asphalt and/or asphalt overlay throughout the District Service Area. The CHWD Operations work crews are involved in daily maintenance of the CHWD underground water infrastructure. This includes, but is not limited to, asphalt street and driveway excavation for repair and/or replacement work to CHWD's underground infrastructure. After CHWD repairs and/or replaces the underground infrastructure within an asphalt area, a contractor, hired by CHWD, will follow up with asphalt restoration as necessary. CHWD currently does not have the equipment and the qualified staff to restore asphalt on an as needed basis; therefore, contracting out asphalt restoration work is essential. The District received three (3) sealed proposals on March 29, 2016, at which time proposals were opened and read publicly. The apparent low bidder is Martin Brothers Construction of Sacramento, CA. Bids received are as follows:

| <u>Bidder</u> | <u>Unit \$/SF</u> | <u>\$/10,000 SF</u> |
|---|-------------------|---------------------|
| 1. Martin Brothers Construction | \$12.59 | \$125,900.00 |
| 2. Central Valley Engineering & Asphalt, Inc. | \$12.90 | \$129,000.00 |
| 3. Arrow Construction | | -Non-Responsive- |

ACTION: Director Sheehan moved and Director Riehle seconded the motion to: Accept the bid of Martin Brothers Construction in the amount of \$12.59 per square foot. Authorize the General Manager to execute the Agreement for Construction Services.

The motion carried 3-0 with all Directors voting yes.

Mariposa Avenue 12-Inch Main Project (A)

Consider acceptance of a bid to replace a 12-inch transmission main along Mariposa Avenue between Northridge Drive and Farmgate Way and along Mariposa Avenue between Eastgate Avenue and Northeast Circle (South) in the City of Citrus Heights.

Project Plans were prepared by KASL Consulting Engineers and the District Engineering Department and distributed to twenty-three contractors and three material suppliers for installing and connecting approximately 1,471 lineal feet (lf) of 12-inch water main, 110 lineal feet (lf) of 8-inch water main, 43 lineal feet (lf) of 6-inch water main and related appurtenances along Mariposa Avenue between Northridge Drive and Farmgate Way and along Mariposa Avenue between Eastgate Avenue and Northeast Circle (South) in the City of

Citrus Heights.

The District received seven (7) sealed proposals on April 5, 2016, at which time proposals were opened and read publicly. The apparent low bidder is Civil Engineering Construction, Inc. of Loomis, CA. Bids received are as follows:

| | |
|--|----------------------|
| 1. Civil Engineering Construction, Inc. | \$ 442,685.00 |
| 2. RTC Construction Management | \$ 446,927.90 |
| 3. Lamon Construction, Inc. | \$ 480,000.00 |
| 4. Rawles Engineering, Inc. | \$ 492,630.00 |
| 5. Cal Sierra Construction, Inc. | \$ 513,705.00 |
| 6. JJM Engineering Constructors, Inc. | \$ 517,613.00 |
| 7. Lund Construction, Inc. | \$ 699,233.00 |

The District's final engineering estimate (March 2016) for this Project was \$460,000.

ACTION: Director Riehle moved and Director Sheehan seconded the motion to: Accept the bid of Civil Engineering Construction, Inc. in the amount of \$442,685.00 and establish a change order contingency fund in the amount of \$44,000.00 (9.9%). Authorize the General Manager to execute the contract.

The motion carried 3-0 with all Directors voting yes.

Water Conservation (D)

Discuss history of the District's water conservation ordinance, the District's Current water conservation stage declaration and the proposed adoption of new water conservation ordinance. On April 2nd, 1991 the District's Board of Directors adopted Ordinance No. 02-91 to establish the District's water conservation requirements, including enforcement measures, to be implemented to reduce water consumption within the District, recognizing that water is a valuable natural resource which should not be wasted, further recognizing that the District is resolved to provide its customers with high quality water for domestic, commercial, irrigation, and fire protection purposes at adequate pressures and equitable rates and further recognizing that water availability can be adversely affected by weather conditions, environmental commitments, a depleting ground-water basin, and growth. The District's philosophy over the years has been to enforce the conservation stage requirements with a "coach to correct approach" rather than a "penalty enforcement approach". Customers are offered educational materials, advice covering how to improve indoor and outdoor water efficiency and a free water efficiency review. Due to the District's "coach to correct approach" the enforcement measures were available but rarely used. To date the coach to correct philosophy has been successful with our customers. Since Ordinance 02-91 was adopted, amendments and revisions to the ordinance and enforcement measures were adopted by resolutions.

Procedural Correction:

- Rescind Ordinance 02-91 by creating an updated Ordinance
- Update Water Conservation Stage language
- Insert updated enforcement measures including progressive monetary penalties
- Consider enforcement policy options and possible ramifications

- Adopt ordinance 05-16 to replace ordinance 02-91
- Moving forward use resolutions to declare or change a current stage declaration

At least 10 days before consideration of adoption of an ordinance, a Notice of Public Hearing should be published in a newspaper of general circulation. A certified copy of the full text of the ordinance (or summary) should be posted in the CHWD offices at least 5 days prior to the hearing. Within 15 days after adoption of the ordinance or amendment, the board shall publish a summary of the ordinance with the names of those directors voting for and against the ordinance.

ACTION: Director Riehle moved and Director Sheehan seconded the motion to: Call for a public hearing.

The motion carried 3-0 with all Directors voting yes.

Strategic Planning (A)

Consider dates to schedule Strategic Planning Sessions. AGM Straus provided an overview of the two day Strategic Planning session. Board Members provided input regarding team building component. Staff will finalize dates with the Board and District Staff.

PROJECT MANAGER'S REPORT

PM Dietrich presented a report on the following activities during the month of March 2016 by the Project Management and Engineering Department.

New values or projects noted in bold italics

PM-1 ACCEPTED WATER SYSTEMS

Recent additions to the District's water distribution system that were constructed by independent State Licensed contractors on behalf of private developers / owners, inspected by the District and formally accepted:

| <u>Project</u> | <u>Count</u> | <u>Facilities</u> | <u>Value</u> |
|----------------|--------------|-------------------|--------------|
|----------------|--------------|-------------------|--------------|

None

PM-2 PROJECTS UNDER CONSTRUCTION BY PRIVATE DEVELOPERS

Water distribution system facilities currently under construction by independent State Licensed contractors on behalf of private developers / owners requiring District inspection:

| <u>Project</u> | <u>Location</u> | <u>Status</u> |
|---|------------------|--|
| The Village at Fair Oaks 55 Condominiums | 6800 Madison Ave | <i>Ongoing Development. Inspecting Finished Phases as Released.</i> |

| <u>Project</u> | <u>Location</u> | <u>Status</u> |
|---|-----------------------------|---------------------------------|
| California American Water Co. San Juan Avenue Tank - Intertie and Water Service | 5444 San Juan Ave | 75% Complete |
| Capitol Nursery Plaza | Sunrise Blvd @ Madison Ave | 85% Complete |
| Sylvan Middle School | 7085 Auburn Blvd | Substantially Complete |
| Citrus Heights City Hall | 6350 Fountain Square Dr | 80% Complete |
| Northridge Grove 47 Condominiums | 5555 Mariposa Ave | Awaiting System Construction |
| Memory Care Facility | 6825-33 Sunrise Blvd | 50% Complete |
| Applebee's Restaurant | 6900 Auburn Blvd | Substantially Complete |
| Dundee Estates | Mariposa Ave @ Highland Ave | 80% Complete |

PM-3 CONTRACTOR / DEVELOPER PROJECTS PENDING CONSTRUCTION

| <u>Project</u> | <u>Location</u> | <u>Status</u> |
|--|-------------------------------|---|
| McDonalds (2015-60) | 5402 Sunrise Blvd | Awaiting System Construction |
| Bearpaw Expansion Commercial Building (2015-59) | 7524 Old Auburn Rd | Awaiting System Construction |
| Louis-Orlando Bus Transfer Point (2015-66) | Louis Ln @ Orlando Ave | Awaiting System Construction |

PM-4 PROPOSED DISTRICT CAPITAL IMPROVEMENT PROJECTS

Project Plans and Contracts currently under review and development by the Engineering Department:

| <u>Project</u> | <u>Location</u> | <u>Status</u> |
|--|---|--|
| Mesa Verde High School 14" Water Main | Northwest Corner of Property West from Poplar Avenue | Preparing to Restart Project in May |
| Bennett Engineering Services Fair Way Intertie with | 9955 Fair Way | Agreement – 99% |

| <u>Project</u> | <u>Location</u> | <u>Status</u> |
|---|---|---|
| City of Roseville | | Plans – 95% Cost Estimate – 90% |
| Blossom Hill Dr Intertie with City of Roseville | Blossom Hill Dr at 1100 Main Sail Cir | Agreement – 99% Plans – 95% Cost Estimate – 90% |
| Crestmont Ave Intertie with City of Roseville | Crestmont Ave at 8199 Bonnie Oak Way | Agreement – 99% Plans – 95% Cost Estimate – 90% |
| Mariposa Ave, Limerick Way and Dublin Way Water Mains KASL Consulting Engineers, Inc. | Limerick Way to Farmgate Way and Eastgate Ave to Northeast Circle (south end) | Mariposa Ave Portion - Bid Opening on April 5th. Limerick Way Portion – 90% Plans Delivered to KASL on March 30th. |
| Baird Way 12” Water Main Area West Engineers, Inc. | Auburn Blvd to Holly Dr | 60% Plan Development Continues |

PM-5 PROJECTS CONTRACTED BY CITRUS HEIGHTS WATER DISTRICT

Capital Improvement Projects currently under construction by Citrus Heights Water District contractors requiring coordination and inspection by the District:

| <u>Project</u> | <u>Location</u> | <u>Status</u> |
|---|--|--|
| San Juan Park 12” Water Main KASL Consulting Engineers, Inc. San Juan High School 24” Water Main Lamon Construction Company | 5555 Mariposa Ave to U.C. Davis Medical Center Along North Property Line | Substantially Complete Final Approval March 3, 2016. Notice of Completion April 12, 2016. |

PM-6 CITY OF CITRUS HEIGHTS PROJECTS

City of Citrus Heights Projects requiring coordination and inspection by the District:

None

OPERATIONS MANAGER’S REPORT

Interim Operations Manager David Gordon reported as follows:

A total of 230 work orders were performed during the month of March by field operations crews, administration field crews and contractors. The results of recent bacteriological testing, a total of 72 samples, have met all California Department of Public Health requirements.

District-wide water consumption for the calendar year 2016 through the end of March was 517.56 acre-feet, a decrease of 36.8% percent compared with the water consumption during the same period in 2013.

As of midnight on April 4, 2016, storage in Folsom Lake was at 711,948 acre-feet, 73 percent of the total capacity of 977,000 acre-feet. This is about 111 percent of historical average for this date. This represents an increase in storage of 106,393 acre-feet in the past month.

The state-wide snow pack data, as of April 4, 2016, was 81% of normal.

Director Dains called a recess to the meeting at 8:58 PM.

PM Dietrich and IOM Gordon left the meeting.

Director Dains reconvened the meeting at 9:06 PM.

DIRECTOR'S AND REPRESENTATIVES REPORTS:

- D-1. Regional Water Authority (Dains, Churchill)
Director Dains and Churchill stated no updates.
- D-2. Sacramento Groundwater Authority (Sheehan)
Director Sheehan reported that the next meeting will be Thursday so there are no new updates.
- D-3. San Juan Water District
GM Churchill reported that both San Juan Water District and the Regional Water Authority are moving forward with their water reliability studies.
- D-4. Association of California Water Agencies (Dains)
No report.
- D-5. ACWA Joint Powers Insurance Authority (Churchill)
No report.
- D-6. Sacramento Local Agency Formation Commission
Director Riehle attended his first meeting and requested information regarding what they represented.
- D-7. City of Citrus Heights
It was reported that the City is beginning evaluating a street improvement project on Auburn Blvd. from Rusch Park North to the City limit.
- D-8. Chamber of Commerce Government Issues Committee (Straus)
No report.

D-9. Other Reports:
None

ASSISTANT GENERAL MANAGER'S REPORT

AGM Straus reported as follows:

Water Efficiency Program activities during the month of March 2016 included:

- 18 ultra-low-flush toilet rebates for the month of March. A total of \$4,500 in rebates has been provided to customers during 2016 to date.
- For the period of March 2016, 9 High Efficiency Clothes Washer (HECW) rebates were processed by SMUD for District customers.
- 18 water waste calls were received during the month of March. No reports of water waste were received through the CHWD's Drought Resources web page. A total of 12 contacts (mostly visits to customers' homes and phone calls) have been completed based on these reports.
- RWA distributed a template letter for its member agencies to customize and send to the State Water Resource Control Board (SWRCB) concerning statewide conservation enforcement measures. GM Churchill will send a comment letter on the District's behalf. Comment letters are due to the SWB by noon on Thursday, April 14, 2016. We will plan to share a draft letter with the Board next Tuesday evening. Also, RWA is sending its own letter on behalf of the region. There will be a SWRCB State Water Board workshop on April 20th. It is anticipated that the current State conservation measures will be discussed.
- The March 2016 Residential Gallon per Capita per Day (R-GPCD) was 77. February 2016 Residential Gallon per Capita per Day (R-GPCD) was 77. January 2016 Residential Gallon per Capita per Day (R-GPCD) was 80. December 2015 the R-GPCD was 75. November 2015 82 October 2015 the R-GPCD was 140. September R-GPCD was 160. August the R-GPCD was 172. The July R-GPCD was 176. The June R-GPCD 2015 was 163. The May R-GPCD was 129. The April R-GPCD was 117. The March R-GPCD was 108. The February R-GPCD 83. The January R-GPCD was 75. The December 2014 was 84. The November was 98, and October was 153. This information is submitted monthly to the State Water Resources Control Board.

The following is a summary of Drought Response Plan activities in March:

- CHWD's Water Reduction Target for 2016 has been reduced from 32% to 29%. A 3% target decrease was given to the region based on Sacramento's arid climate. June through September 2016 will be the months the required targets will be monitored for compliance by the SWRCB.

- Based on the current required 29% water reduction target issued by the SWRCB and current rainfall/snowpack totals, WEC Meurer recommends continuing with a Stage 4 Water Crisis through 2016. A formal recommendation will be brought to the Board at the April and May Board meetings as part of the Board’s consideration of drought enforcement policies.

Paladin Night Patrol began conducting night time water waste monitoring on July 29th, 2015. Below is a chart illustrating the number of incidents reported by category for August 2015 through March 2016.

| Date | *Incident Report | Wrong Day | Equipment Waste | Theft |
|-----------------------|------------------|-----------|-----------------|----------|
| AUGUST 2015 | 108 | 79 | 90 | 1 |
| SEPTEMBER 2015 | 96 | 47 | 80 | 0 |
| OCTOBER 2015 | 46 | 37 | 42 | 0 |
| NOVEMBER 2015 | 69 | 15 | 69 | 0 |
| DECEMBER 2015 | 56 | 31 | 54 | 0 |
| JANUARY 2016 | 32 | 15 | 32 | 0 |
| February 2016 | 29 | 18 | 29 | 0 |
| MARCH 2016 | | | | |

*A single incident report can include one or more violation categories. One incident report can overlap into multiple categories.

GENERAL MANAGER’S REPORT

- Twenty two employees received recognition for superior attendance, outstanding customer service and quality of work during the month of March 2016. Directors were provided with a list of the employees and items for which each received recognition.
- A list of the General Manager’s significant assignments and activities was provided.
- Long Range Board Agenda.

| Meeting Date | Item | Assigned To |
|--------------|--|--------------------|
| May 10, 2016 | Employment Agreements— Department Heads and Policy Updates | Churchill/Phillips |
| | Compensation Study, Phase 2 | Churchill/Straus |
| | Water Supply Reserve Policy | Churchill |

| | | |
|--------------------|--|---|
| | Roseville Intertie Agreement | Churchill |
| | CIP Adoption | All |
| | CY 2015 Audit | Straus/Deano |
| | UWMP Study Session/Call for Public Hearing | Straus/Meurer |
| | Water Efficiency Enforcement Ordinance | Straus/Meurer |
| | PHG/Call for Public Hearing | Gordon/Hensley |
| | Auction Items | Gordon |
| | Well Test Hole Bids | Gordon |
| | GM Evaluation—Closed Session | Churchill |
| May-July TBD 2016 | Strategic Planning | Board & GM, Dept. Heads, Supervisors, ACE Pieri and WEC Meurer (13) |
| June 14, 2016 | UWMP Public Hearing/Adoption | Straus/Meurer |
| | Public Health Goals (PHG) Public Hearing | Gordon/Hensley |
| | Third Party Deposit Policy | Straus/Sohal |
| August 9, 2016 | Budget & Rates Study Session | Straus/Sohal |
| September 13, 2016 | Budget and Rates Workshop | Straus/Sohal |
| October 11, 2016 | | |
| November 8, 2016 | Operating and Capital Budgets | Straus/Dietrich/Gordon |
| | Water Rates, Charges & Fees | Straus/Sohal |
| | Capacity Fees | Straus/Sohal |
| | Water Shortage Charges | Straus/Sohal |
| December 13, 2016 | | |

- San Juan Water District has embarked on a Wholesale Water Management and Reliability Study and has selected MWH Engineers to conduct the Study. A meeting with the wholesale customer agencies at 11:00 am on Monday March 14, 2016 was held and attended by Director Sheehan, GM Churchill and OM Gordon. The purpose of the meeting was to develop a short, prioritized list of water management options to improve water supply reliability, and recommendations for the next phase.

CORRESPONDENCE:

None.

Request for a special meeting regarding succession planning was approved for Monday April 18, 2016 at 6:30 PM. This meeting will be held in closed session

FUTURE CHWD BOARD OF DIRECTORS MEETING DATES

Dates and locations of upcoming Regular Meetings of the Board of Directors were noted for the calendar.

ADJOURNMENT

There being no other business to come before the Board, the meeting was adjourned at 10:00 PM.

APPROVED:

ROBERT A. CHURCHILL
Secretary
Citrus Heights Water District

ALLEN B. DAINS, President
Board of Directors
Citrus Heights Water District

DRAFT

CITRUS HEIGHTS WATER DISTRICT
BOARD OF DIRECTORS SPECIAL MEETING
April 18, 2016

The Special Meeting of the Board of Directors was called to order at 6:00 p.m. by President Dains and roll was called. Present were:

Allen B. Dains, President
Caryl F. Sheehan, Vice President
Raymond A. Riehle, Director
Robert A. Churchill, General Manager
Hilary M. Straus, Assistant General Manager

PLEDGE OF ALLEGIANCE

Director Dains led the Pledge of Allegiance.

VISITORS

None.

PUBLIC COMMENT

No public comment.

CONSENT CALENDAR

None.

CLOSED SESSION

The Board of Directors adjourned into Closed Session at 6:33 p.m. pursuant to California Government Code Section 54957 regarding Personnel Exemption discussion regarding Public Employee Retirement and Succession.

Present in the Closed Session were Allen B. Dains, President; Caryl F. Sheehan, Vice President; Raymond A. Riehle, Director; Robert A. Churchill, General Manager; and Hilary M. Straus, Assistant General Manager.

Assistant General Manager Hilary Straus left the meeting at 7:50 p.m.

The Board of Directors adjourned from Closed Session into Open Session at 8:54 p.m.

OPEN SESSION

President Dains announced that no reportable action was taken in Closed Session.

FUTURE CHWD BOARD OF DIRECTORS MEETING DATES

Dates and locations of upcoming Regular Meetings of the Board of Directors were noted for the calendar.

ADJOURNMENT

There being no other business to come before the Board, the meeting was adjourned at 8:56 p.m.

DRAFT

CITRUS HEIGHTS WATER DISTRICT
2016 REVENUE ANALYSIS

| Mo-Yr | Actual Revenue | | | | | Budgeted Revenue | Variance | % Collected |
|---------------------------|----------------|------------------|----------------|----------------|------------------|-------------------|------------------|--------------|
| | Jan-16 | Feb-16 | Mar-16 | Apr-16 To Date | Apr-16 To Date | | | |
| Metered Service Charges | 99,738 | 346,471 | 750,526 | 530,498 | 1,727,232 | 7,609,121 | 5,881,889 | 22.7% |
| Metered Water Deliveries | 35,969 | 118,197 | 180,494 | 144,723 | 479,383 | 4,581,136 | 4,101,753 | 10.5% |
| Irrig | | 0 | 0 | | 0 | 0 | 0 | 0.0% |
| Apt/MH | | 0 | 0 | | 0 | 0 | 0 | 0.0% |
| Penalties | 17,458 | 12,003 | 15,564 | 13,906 | 58,930 | 150,000 | 91,070 | 39.3% |
| Interest | | 0 | | 0 | 0 | 0 | 0 | 0.0% |
| New Acct, Fire & Backflow | | | | | | | | |
| Fees | 8,550 | 12,603 | 9,758 | 13,813 | 44,724 | 95,866 | 51,142 | 46.7% |
| WS Install & S&R | 8,360 | 4,598 | 6,501 | 0 | 19,459 | 26,626 | 7,167 | 73.1% |
| Grant Funds | | 540,000 | 0 | 0 | 540,000 | 0 | -540,000 | 0.0% |
| Misc* | 6,052 | 1,416 | 15,603 | 2,318 | 25,390 | 120,510 | 95,120 | 21.1% |
| Connection Fees | 15,037 | 6,683 | 6,683 | 0 | 28,403 | | | |
| Wheeling Water | 2,217 | 0 | 0 | 0 | 2,217 | 4,429 | 2,212 | 50.1% |
| Reserves | | | | 0 | 0 | 0 | 0 | 0.0% |
| Total | 193,380 | 1,041,971 | 985,129 | 705,258 | 2,925,738 | 12,587,688 | 9,661,950 | 23.2% |

| Collections Activity | Total |
|--------------------------|-------------------|
| Outstanding A/R | 1,064,034 |
| Outstanding Liens | 0 |
| Outstanding Grants | 1,173 |
| Less Unapplied Payments | 101,610 |
| Total₁ | \$ 963,598 |

| Aged Trial Balance | | | | | |
|--------------------|---------|--------|--------|-----------|----------------|
| | Current | 31-90 | 91-150 | >150 | Deposit Amount |
| Total ₁ | 412,430 | 94,966 | 8,688 | 11,649 | 239,818 |
| | | | | (101,247) | |

* Includes Assessments, Inclusions, Back Charges, Capacity Fees and other Miscellaneous Revenue Sources

¹ Discrepancy in Totals from aged trial balance tying to the general ledger balance about \$537,000. Discrepancy maybe due to system reporting error.

| Assessor/Collector Roll Adjustment | | |
|---|-----------------|--------------|
| April-16 | | |
| | Dollar | Count |
| DEFAULT | | |
| One time courtesy | \$ 35.53 | 9 |
| DEFAULT Total | 35.53 | 9 |
| Grand Total | \$ 35.53 | 9 |

ASSESSOR/COLLECTOR'S ROLL ADJUSTMENTS FOR
April 30, 2016

Board Of Directors
Citrus Heights Water District

Pursuant to Policy No. 7315 the following charges have been cancelled.

| LID | CID | Charge Type | Date | Reason For Cancellation | Amount |
|-------|---------|-------------|-----------|-------------------------|-----------------|
| 09700 | 0008611 | DEFAULT | 4/4/2016 | One time courtesy | 3.52 |
| 05595 | 0018872 | DEFAULT | 4/4/2016 | One time courtesy | 4.58 |
| 12900 | 0029784 | DEFAULT | 4/5/2016 | One time courtesy | 3.53 |
| 12781 | 0016428 | DEFAULT | 4/5/2016 | One time courtesy | 3.84 |
| 15425 | 0006788 | DEFAULT | 4/6/2016 | One time courtesy | 3.99 |
| 09452 | 0008461 | DEFAULT | 4/12/2016 | One time courtesy | 6.42 |
| 11607 | 0032256 | DEFAULT | 4/20/2016 | One time courtesy | 4.11 |
| 05447 | 0033228 | DEFAULT | 4/20/2016 | One time courtesy | 3.35 |
| 19107 | 0023192 | DEFAULT | 4/28/2016 | One time courtesy | 2.19 |
| | | | | | <u>\$ 35.53</u> |

**TREASURER'S REPORT TO THE BOARD OF DIRECTORS
CITRUS HEIGHTS WATER DISTRICT
Month of April 2016**

| | | | |
|---|-----------|-----------|-------------|
| Bank of the West | | | |
| Balance Per Bank April 2016 | | | \$3,507,825 |
| RECEIPTS: | | | |
| | | 873,426 | |
| DISBURSEMENTS: | | | |
| Checks Issued / ACH Payments | 1,940,152 | | |
| Payroll | 184,747 | | |
| Returned Checks | 376 | | |
| | | 2,125,275 | (1,251,849) |
| Bank of the West reconciled to books | | | |
| Balance per Bank April 30, 2016 | | | 2,255,976 |
| Add :Outstanding Checks | | | 162,404 |
| Less: Deposit in Transit | | | (14,373) |
| Balance Per Books April 30, 2016 | | | \$2,404,007 |
| RECONCILEMENT: | | | |
| Bank of the West | | | \$2,404,007 |
| Local Agency Investment Fund | | | 6,046,968 |
| COP Reserve Account | | | 533,345 |
| Money Mkt Activity Account | | | 530,426 |
| TOTAL BALANCE | | | \$9,514,746 |

CASH & INVESTMENT SUMMARY:

| | |
|------------------------------------|-------------|
| Bank of the West (General Account) | \$2,404,007 |
| Local Agency Investment Fund | 6,046,968 |
| COP 2010 Reserve Account | 533,345 |
| Money Mkt Activity Account | 530,426 |
| Total | \$9,514,746 |

| INSTITUTION | MATURITY DATE | INT RATE | DEPOSIT AMOUNT | DATE OF LAST TRANSACTION |
|------------------------------|------------------|-------------|-------------------|-----------------------------|
| Local Agency Investment Fund | Daily | 0.32% | 4,928.02 | 1/14/2016 |

I certify that this report accurately reflects all pooled investments and is in compliance with applicable State of California Government Codes and is in conformity with Investment of District Funds Policy 6300. As Treasurer of the Citrus Heights Water District, I hereby certify that sufficient investment liquidity and anticipated revenue are available to meet the next six months' estimated expenditures.



SUSAN K. SOHAL, Deputy Treasurer



HILARY M. STRAUS, Deputy Secretary

TREASURER'S REPORT OF FUND BALANCES
April 30, 2016

| | Beginning Balance 1/1/2016 | Year to Date Transfers In / Collections | Year to Date Transfers Out | Current Month Transfers In / Collections | Current Month Transfers Out | 4/30/2016 Ending Balance | 2016 Target Balance per Policy |
|-------------------------------------|-------------------------------|---|-------------------------------|--|--------------------------------|-----------------------------|--------------------------------------|
| Connection Fund | \$ - | | | | | \$ - | N/A |
| Operating Fund | \$ 3,611,289 | | | | | \$ 3,611,289 | |
| Operating Reserve | \$ 1,912,263 | | | | | \$ 1,912,263 | N/A |
| Rate Stabilization Fund | \$ 634,000 | | | | | \$ 634,000 | |
| Depreciation Reserve | \$ 808,169 | | | | | \$ 808,169 | |
| Capital Improvement Reserve | \$ 845,857 | | | | | \$ 845,857 | |
| Restricted for Debt Service | \$ 536,963 | | | | | \$ 536,963 | N/A |
| Fleet Equipment Reserve | \$ 291,569 | | | | | \$ 291,569 | |
| Employment-Related Benefits Reserve | \$ 396,310 | | | | | \$ 396,310 | |
| | <u>\$ 9,036,420</u> | <u>\$ -</u> | <u>\$ -</u> | <u>\$ -</u> | <u>\$ -</u> | <u>\$ 9,036,420</u> | |

CITRUS HEIGHTS WATER DISTRICT
2016 OPERATING EXPENDITURE VS BUDGET
April 30, 2016

| Account | Description | 2016 MTD Expense | 2016 YTD Expense | 2016 Budget | Variance \$ | Variance % |
|--|--|---------------------|---------------------|------------------|------------------|--------------|
| Water Demand Management | | | | | | |
| | WATER DEMAND MANAGEMENT - POSTAGE | - | - | 14,000 | 14,000 | 0.0% |
| | WATER DEMAND MANAGEMENT - PRINTING | - | 2,554 | 25,000 | 22,446 | 10.2% |
| | WATER DEMAND MANAGEMENT - MATERIALS AND SUPPLIES | 4,687 | 4,987 | 11,500 | 6,513 | 43.4% |
| | WATER DEMAND MANAGEMENT - CONTRACT SERVICES | 17,534 | 41,874 | 221,000 | 179,126 | 18.9% |
| | WATER DEMAND MANAGEMENT - OTHER | 500 | 3,774 | 8,000 | 4,226 | 47.2% |
| | WATER DEMAND MANAGEMENT - INCENTIVE PROGRAMS | - | 3,150 | 3,000 | (150) | 105.0% |
| | | 22,721 | 56,338 | 282,500 | 226,162 | 19.9% |
| Operations | | | | | | |
| | PURCHASED WATER | 432,773 | 895,890 | 2,387,701 | 1,491,811 | 37.5% |
| | COOPERATIVE TRANSMISSION PIPELINE MAINTENANCE | - | - | 5,000 | 5,000 | 0.0% |
| | POWER TO WELLS | 9,251 | 36,258 | 244,904 | 208,646 | 14.8% |
| | WELLS - REPAIR / MAINTENANCE | - | 1,219 | 22,000 | 20,781 | 5.5% |
| | WATER QUALITY ANALYSIS | 2,968 | 7,650 | 41,000 | 33,350 | 18.7% |
| | FIELD MISCELLANEOUS - DUMP FEES | - | 812 | 1,000 | 188 | 0.0% |
| | FIELD MISCELLANEOUS - OTHER | - | 16 | 1,000 | 984 | 1.6% |
| | SMALL TOOLS - FIELD | 3,683 | 11,261 | 23,400 | 12,139 | 48.1% |
| | SUPPLIES - FIELD | 1,166 | 7,323 | 19,000 | 11,677 | 38.5% |
| | MATERIALS | 15,570 | 111,397 | 6,000 | (105,397) | 1856.6% |
| | MATERIALS (Allocation to CIP) | (14,519) | (59,805) | - | - | 0.0% |
| | ROADBASE | 1,242 | 10,926 | 20,000 | 9,074 | 54.6% |
| | MAINTENANCE AGREEMENTS - EQUIPMENT | 2,551 | 3,388 | 6,700 | 3,312 | 50.6% |
| | MAINTENANCE AGREEMENTS - SOFTWARE | 669 | 109,221 | 1,343,322 | 1,234,101 | 8.1% |
| | REPAIR - FLEET EQUIPMENT | (328) | 14,980 | 40,000 | 25,020 | 37.5% |
| | REPAIR - TOOLS AND EQUIPMENT | 2,400 | 9,636 | 12,000 | 2,364 | 80.3% |
| | GAS AND OIL | 1,461 | 8,508 | 51,000 | 42,492 | 16.7% |
| | EQUIPMENT RENTAL - FIELD | 114 | 3,690 | 3,000 | (690) | 123.0% |
| | EQUIPMENT RENTAL & MAINT - OFFICE & BUILDING EQUIP | 302 | 2,978 | 14,366 | 11,388 | 20.7% |
| | EQUIPMENT (Allocation to CIP) | (14,519) | (59,805) | - | - | - |
| | PERMIT FEE - AIR QUALITY / HAZ MAT | - | 2,374 | 5,700 | 3,327 | 41.6% |
| | PERMIT FEE - STATE WATER RESOURCES CONTROL BOARD (SWRCB) | 5,600 | 6,618 | 14,000 | 7,382 | 47.3% |
| | PERMIT FEE - ENCROACHMENT PERMITS | - | 4,008 | 44,000 | 39,992 | 9.1% |
| | | 450,383 | 1,128,541 | 4,305,093 | 3,056,942 | 26.2% |
| Professional & Contract Services | | | | | | |
| | PROFESSIONAL / CONTRACT SERVICES - ENGINEERING | - | (1,875) | 20,000 | 21,875 | -9.4% |
| | PROFESSIONAL / CONTRACT SERVICES - TEMPORARY LABOR | 9,840 | 39,810 | 50,000 | 10,190 | 79.6% |
| | PROFESSIONAL / CONTRACT SERVICES - WELLS | - | - | - | - | 0.0% |
| | PROFESSIONAL / CONTRACT SERVICES - OFFICE LABOR | 9,344 | 48,445 | 130,000 | 81,555 | 0.0% |
| | PROFESSIONAL / CONTRACT SERVICES - METER READING | 6,280 | 35,114 | 108,960 | 73,846 | 32.2% |
| | PROFESSIONAL / CONTRACT SERVICES - BILL PRINT/MAIL | 1,791 | 11,996 | 27,600 | 15,604 | 43.5% |
| | PROFESSIONAL / CONTRACT SERVICES - FINANCIAL | - | 1,480 | 5,000 | 3,520 | 0.0% |
| | PROFESSIONAL / CONTRACT SERVICES - OTHER | 9,603 | 47,842 | 133,460 | 85,618 | 35.8% |
| | CONTRACT SERVICES - CONCRETE | - | - | 8,000 | 8,000 | 0.0% |
| | CONTRACT SERVICES - MISC FIELD / O&M | 3,988 | 13,260 | 30,000 | 16,740 | 44.2% |
| | CONTRACT SERVICES - OFFICE REPAIRS / MAINT | 198 | 1,099 | 2,000 | 901 | 55.0% |
| | CONTRACT SERVICES - PAVING | - | 1,791 | 9,000 | 7,209 | 19.9% |
| | | 41,044 | 198,962 | 524,020 | 325,058 | 38.0% |
| Administration & General Services | | | | | | |
| | JANITORIAL | 542 | 2,753 | 11,100 | 8,347 | 24.8% |
| | BANK FEES | 4,286 | 24,226 | 71,000 | 46,774 | 34.1% |
| | OFFICE EXPENSE | 1,555 | 5,445 | 15,000 | 9,555 | 36.3% |
| | SMALL OFFICE EQUIPMENT | - | 4,551 | 2,000 | (2,551) | 227.6% |
| | DUES & SUBSCRIPTIONS | 2,408 | 55,184 | 112,210 | 57,026 | 49.2% |
| | POSTAGE | 7,858 | 39,839 | 103,000 | 63,161 | 38.7% |
| | PRINTING | 174 | 610 | 7,700 | 7,090 | 7.9% |
| | TELEPHONE - WIRELESS | 1,116 | 4,705 | 16,800 | 12,095 | 28.0% |
| | TELEPHONE - LOCAL / LONG DISTANCE | 9,165 | 9,411 | 12,500 | 3,089 | 75.3% |
| | TELEPHONE - ANSWERING SERVICE | 152 | 461 | 2,400 | 1,939 | 19.2% |
| | UTILITIES | 1,881 | 7,758 | 19,700 | 11,942 | 39.4% |

CITRUS HEIGHTS WATER DISTRICT
 2016 OPERATING EXPENDITURE VS BUDGET
 April 30, 2016

| Account | Description | 2016 MTD Expense | 2016 YTD Expense | 2016 Budget | Variance \$ | Variance % |
|--------------------------|--|------------------|---------------------|----------------------|---------------------|---------------|
| | LEGAL & AUDIT | 5,233 | 31,163 | 78,900 | 47,737 | 39.5% |
| | CONTINUED EDUCATION | 957 | 7,305 | 45,780 | 38,475 | 16.0% |
| | PUBLICATION NOTICES | 68 | 143 | 1,500 | 1,357 | 9.6% |
| | OFFICE MISC - DISTRICT EVENTS | 160 | 872 | 5,110 | 4,239 | 17.1% |
| | OFFICE MISC - MEETING ACCOMODATIONS | 100 | 257 | 2,000 | 1,743 | 12.9% |
| | OFFICE MISC - OTHER | 692 | 978 | 2,200 | 1,222 | 44.5% |
| | OFFICE MISC - MILESTONE EVENTS | - | - | 5,100 | 5,100 | 0.0% |
| | BAD DEBT EXPENSE | - | 192 | 5,000 | 4,808 | 3.8% |
| | COMPUTER SOFTWARE | - | 250 | 3,700 | 3,450 | 6.8% |
| | | 36,347 | 196,107 | 522,700 | 326,593 | 37.5% |
| Administration Other | | | | | | |
| | ELECTION EXPENSE | - | - | 29,000 | 29,000 | 0.0% |
| | DIRECTORS MEETING COMPENSATION | 1,885 | 4,205 | 20,300 | 16,095 | 20.7% |
| | RETIREE HEALTH CARE BENEFIT | 2,991 | 11,563 | 43,547 | 31,984 | 26.6% |
| | | 4,876 | 15,768 | 92,847 | 77,079 | 17.0% |
| Salary & Benefits | | | | | | |
| | SALARY - GENERAL MANAGER | 14,022 | 52,542 | 162,016 | 109,474 | 32.4% |
| | SALARY - MANAGER (3 authorized positions) | 18,235 | 39,344 | 219,132 | 179,788 | 18.0% |
| | SALARY - OFFICE (6 authorized positions) | 28,586 | 68,333 | 374,100 | 305,767 | 18.3% |
| | SALARY -WATER DEMAND MANAGEMENT (2 authorized positions) | 10,966 | 41,440 | 156,088 | 114,648 | 26.5% |
| | SALARY - FIELD / O&M (15 authorized positions) | 81,193 | 306,967 | 1,118,893 | 811,926 | 27.4% |
| | STANDBY DUTY | 1,380 | 5,430 | 17,940 | 12,510 | 30.3% |
| | SALARY - PROJECT MNGMT & ENGINEERING | 18,725 | 76,850 | 315,145 | - | 0.0% |
| | EMPLOYEE BENEFIT - VISION INSURANCE | 753 | 4,948 | 5,100 | 152 | 97.0% |
| | EMPLOYEE BENEFIT - DENTAL INSURANCE | 2,990 | 24,248 | 43,200 | 18,952 | 56.1% |
| | EMPLOYEE BENEFIT - HEALTH INSURANCE | 29,046 | 129,145 | 375,272 | 246,127 | 34.4% |
| | EMPLOYEE BENEFIT - PERS RETIREMENT | 24,315 | 237,972 | 422,544 | 184,572 | 56.3% |
| | EMPLOYEE BENEFIT - SOCIAL SECURITY | 10,972 | 41,325 | 153,444 | 112,119 | 26.9% |
| | EMPLOYEE BENEFIT - MEDICARE | 2,566 | 9,665 | 35,886 | 26,221 | 26.9% |
| | EMPLOYEE BENEFIT - UNEMPLOYMENT INSURANCE | 116 | 5,646 | 7,875 | 2,229 | 71.7% |
| | EMPLOYEE BENEFIT - HEALTH INSURANCE REIMBURSEMENT | 2,506 | 10,570 | 26,000 | 15,430 | 40.7% |
| | EMPLOYEE SALARY AND BENEFITS - (Allocation to CIP) | (36,777) | (210,067) | (339,867) | (129,800) | 61.8% |
| | | 209,594 | 844,357 | 3,092,768 | 2,010,115 | 27.3% |
| Insurance | | | | | | |
| | INSURANCE - LIABILITY & COMPREHENSIVE | - | 78,001 | 75,300 | (2,701) | 103.6% |
| | INSURANCE - DISABILITY & LIFE | 5,072 | 13,429 | 28,300 | 14,871 | 47.5% |
| | INSURANCE - WORKER'S COMPENSATION | - | - | 54,319 | 54,319 | 0.0% |
| | | 5,072 | 91,429 | 157,919 | 66,490 | 57.9% |
| Reserves & Debt Services | | | | | | |
| | RATE STABILIZATION RESERVE | - | - | - | - | 0.0% |
| | DEPRECIATION RESERVE | - | - | 1,001,744 | 1,001,744 | 0.0% |
| | CAPITAL IMPROVEMENT RESERVE | - | - | 1,000,000 | 1,000,000 | 0.0% |
| | EMPLOYMENT-RELATED BENEFITS RESERVE | - | - | - | - | 0.0% |
| | DEBT SERVICE - COP SERIES 2010 | - | 50,503 | 571,200 | 520,697 | 8.8% |
| | DEBT SERVICE - COP SERIES 2012 | - | 122,436 | 169,063 | 46,627 | 72.4% |
| | | - | 172,938.68 | 2,742,007.00 | 2,569,068.32 | 6.3% |
| | | 770,036 | \$ 2,704,442 | \$ 11,719,854 | \$ 8,657,507 | 23.08% |

Citrus Heights Water District
 Capital Projects Summary
 Fiscal Period End as of April 2016

| Project No. | Description | Budget | | Remaining Commitments | | Amounts Paid | | Remaining Projections 2017 | |
|-------------|--|----------------------|---------------------|-------------------------|-----------------------------|--------------------------|---------------|----------------------------|------------------|
| | | Total Project Budget | Adopted Budget 2016 | Expenditures to 12/2015 | Total Remaining Commitments | Current Unpaid Committed | Month to Date | | Year to Date |
| 2015-31 | Baird Way 12" Water Main Replacement Project | 504,283 | | 5,698 | 498,586 | - | - | 5,698 | 476,781 |
| 2015-32 | Graham Circle 6" and Circuit Drive 8" Water Main Replacement Project | | | | | | | | |
| 2015-33 | Highland Avenue 8" Main Replacement and Rosa Vista Avenue 8" Main Installation Project | 396,672 | 24,619 | - | 396,672 | - | - | - | 372,053 |
| 2015-34 | Michigan Drive 8" / 6" Water Main Replacement Project | | | | | | | | |
| 2015-35 | Sunrise Blvd Streetscape Phase III | | | 162,183 | (162,183) | - | - | - | 163,266 |
| 2015-36 | Sylvan Road Street Improvements | | | 4,161 | (4,161) | - | - | - | 4,161 |
| 2016-31 | Wind Way 8-inch and Longwood Way 6-inch Water Main Replacements | 324,446 | 8,968 | - | 324,446 | - | - | - | - |
| 2016-34 | Auburn Blvd - Rusch Park to Placer County Line | 158,252 | | | 158,252 | - | - | - | - |
| | Distribution Mains - Replacement | 1,383,653 | 33,587 | 172,041 | 728,914 | - | - | 1,083 | 323,446 |
| 2016-14 | Fire Hydrants - Replacements / Upgrades / Infill / New | 147,092 | 147,092 | - | 147,092 | - | - | - | 1,172,280 |
| | Fire Hydrants - Replacements/Upgrades/New | 147,092 | 147,092 | - | 147,092 | - | - | - | - |
| 2015-02 | Annual Corporation Yard Improvements/Replacements | 109,500 | 109,500 | - | 109,500 | - | - | - | - |
| 2015-03 | Annual Fleet and Field Operations Equipment Improvements/Replacements | 32,200 | 32,200 | - | 32,200 | - | - | 8,635 | 75,000 |
| 2015-04 | Annual Technology Hardware and Software Improvements/Replacements | 750,000 | 300,000 | 3,356 | 746,644 | - | - | 3,356 | 450,000 |
| 2016-00 | Water Main Pipeline Replacements | 38,934 | 38,934 | - | 38,934 | - | - | 40,386 | - |
| 2016-10 | Water Main Pipeline Replacements | 28,465 | 28,465 | - | 28,465 | - | - | - | - |
| 2016-11 | Water Valve Replacements | 91,281 | 91,281 | - | 91,281 | - | - | - | - |
| 2016-12 | Water Service Replacements | 757,685 | 757,685 | - | 757,685 | - | - | 5,919 | - |
| 2015-38 | Mariposa Avenue 12" Water Main Replacement Project | 27,111 | 27,111 | - | 27,111 | - | - | - | - |
| 2015-39 | Mariposa Avenue 12" Water Main Replacement Project | 99,057 | 99,057 | 4,064 | (4,064) | - | - | 4,064 | - |
| 2016-40 | Other City Partnership Opportunities | 99,057 | 99,057 | - | 99,057 | - | - | - | - |
| 2016-41 | Other Miscellaneous Infrastructure Projects | 99,057 | 99,057 | - | 99,057 | - | - | - | 149,284 |
| | Miscellaneous Projects | 2,033,290 | 1,583,290 | 7,420 | 2,025,870 | - | - | 54,940 | 674,284 |
| 2012-13 | Administration Building Expansion / Renovation Project | 100,000 | 100,000 | 1,205,171 | - | - | - | 4,670 | - |
| 2015-41 | Other Miscellaneous Infrastructure Projects - Admin Building Extension | | | | | | | 6,086 | - |
| 2016-25 | Other Miscellaneous Infrastructure Projects - Admin Building Extension | | | | | | | 10,756 | 7,093 |
| | Miscellaneous Projects - Facilities | 483,671 | 225,591 | 312,473 | 171,198 | - | - | 13,009 | 409,464 |
| 2013-30 | San Juan High School 24" North Property Line Transmission Main Installation | 348,800 | 198,842 | 177,630 | 171,170 | - | - | 3,293 | 245,114 |
| 2014-36 | Center | 112,335 | 99,655 | 4,756 | 107,579 | - | - | - | 4,756 |
| 2015-30 | Poplar Avenue 14" Transmission Main Installation | 944,806 | 524,088 | 494,858 | 449,948 | - | - | 16,302 | 659,334 |
| 2014-33 | Mariposa Avenue 18" & 8" Sycamore Drive to Pratt Avenue | 775,110 | 775,110 | 414,356 | - | - | - | 15,769 | 430,125 |
| 2016-30 | Mariposa Avenue 12-inch Mains and Limerick Way 8-inch Main Replacements | 775,110 | 775,110 | 10,214 | 764,897 | - | - | 6,634 | 30,587 |
| 2016-13 | Water Meter Replacements | 53,158 | 53,158 | 424,570 | 764,897 | - | - | 6,634 | 460,712 |
| | Water Meters | 53,158 | 53,158 | - | 53,158 | - | - | - | - |
| 2011-01 | Fair Way 12" x 8" interconnection w/ RV | 28,105 | 28,105 | - | 28,105 | - | - | - | - |
| 2012-09 | Blossom Hill Drive 6" x 10" Interconnection w/ RV | 25,480 | 25,480 | - | 25,480 | - | - | - | - |
| 2012-10 | Crestmont Avenue 6" Interconnection w/ RV | 19,980 | 19,980 | - | 19,980 | - | - | - | - |
| 2013-21 | Skycrest Skycrest Construction | 2,081,569 | | 2,145,695 | - | - | - | 234,008 | 2,379,703 |
| 2016-20 | Groundwater Well Improvements | 48,900 | 48,900 | - | 48,900 | - | - | - | - |
| 2015-37 | C-Bar-C Pressure Control Station | 200,000 | 200,000 | - | 200,000 | - | - | - | - |
| | Water Meters - Emergency Inter tie Water Meters | 2,404,034 | 322,465 | 2,145,695 | 322,465 | - | - | 234,008 | 2,379,703 |
| | Grand Total | 7,743,143 | 3,438,790 | 4,449,756 | 4,492,343 | - | - | 33,691 | 4,952,283 |
| | | | | | | | | | 1,846,564 |

APRIL 2016 WARRANTS

| | | | |
|-------|--|------------------------------------|--------------|
| 60844 | Moonlight BPO | Contract Services Bill Print | \$5,382.25 |
| 61338 | Ferguson Enterprises Inc #1423 | Material | \$14,075.64 |
| 61339 | Maze & Associates | Legal & Audit | \$11,648.00 |
| 61340 | Paladin Private Security | Contract Services-Other | \$10,296.00 |
| 61341 | R E Smith Contractor Inc | Contract Services-Wells | \$107,857.14 |
| 61342 | SMUD | Utilities | \$13,471.12 |
| 61343 | Warren Consulting Engineers Inc | Contract Services-Engineering | \$8,635.00 |
| 61344 | Central Valley Engineering & Asphalt, Inc. | Contract Services-Concrete | \$12,045.55 |
| 61345 | ACWA/JPIA | Workers Compensation Insurance | \$10,338.00 |
| 61347 | Derrick/Christina B Casillas | Customer Refund | \$158.93 |
| 61348 | Chino S/Tina T Lee | Customer Refund | \$57.30 |
| 61349 | William G/Elaine A McJunkins | Customer Refund | \$15.86 |
| 61350 | Daniel J Wisbaum | Customer Refund | \$251.66 |
| 61351 | Robert Capobianco | Customer Refund | \$9.85 |
| 61352 | Scott A Wood | Customer Refund | \$207.23 |
| 61353 | Thomas Turner/Laura Alvarado | Customer Refund | \$94.39 |
| 61354 | AFLAC | Employee Paid Insurance | \$375.06 |
| 61355 | Alexander's Contract Services | Contract Services-Meter Read | \$1,667.44 |
| 61356 | Bart/Riebes Auto Parts | Repair-Trucks | \$24.47 |
| 61357 | BSK Associates | Water Analysis | \$216.00 |
| 61358 | California Landscape Associates Inc | Janitorial | \$200.00 |
| 61359 | City of Citrus Heights | Permit Fees | \$150.00 |
| 61360 | Connected Document Solutions | Contract Services-Equipment | \$30.96 |
| 61361 | Robin Cope | Health Insurance | \$402.00 |
| 61362 | Coverall North America Inc | Janitorial | \$450.00 |
| 61363 | Cybex | Office Expense | \$139.45 |
| 61364 | Robyn J Evans | Continued Education | \$63.42 |
| 61365 | J4 Systems | Contract Services-Other | \$2,352.61 |
| 61366 | Kei Window Cleaning #12 | Janitorial | \$92.00 |
| 61367 | Liebert Cassidy Whitmore | Legal & Audit | \$2,040.00 |
| 61368 | Pace Supply Corp | Material | \$139.80 |
| 61369 | Paul N Phillips, Attorney at Law | Legal & Audit | \$4,562.50 |
| 61370 | USPS | Postage | \$228.00 |
| 61371 | Republic Services #922 | Utilities | \$193.92 |
| 61372 | RUE EQUIPMENT | Contract Services-Equipment Repair | \$494.57 |
| 61373 | Sonitrol | Office Expense | \$162.27 |
| 61374 | Titan Workforce LLC | Contract Services-Temporary Labor | \$6,089.88 |
| 61375 | Tree Pros, Inc | Contract Services-Miscellaneous | \$1,300.00 |
| 61376 | Zee Medical Company | Supplies-Field | \$165.68 |
| 61377 | Moonlight BPO | Contract Services Bill Print | \$4,036.71 |
| 61378 | Corix Water Products, Inc | Material | \$2,791.28 |
| 61379 | Allan D Hulme | Customer Refund | \$7.16 |
| 61380 | Warren Adams Inc | Customer Refund | \$29.97 |
| 61381 | Francisco S/Corazon Q Laudato | Customer Refund | \$64.00 |
| 61382 | Jerry/Pam Aplash | Customer Refund | \$15.04 |
| 61383 | Joan A/ Michael L Jones | Customer Refund | \$72.50 |
| 61384 | Michael B Rowland | Customer Refund | \$25.59 |
| 61385 | Todd Sinclair | Customer Refund | \$61.93 |
| 61386 | William R Baird | Customer Refund | \$7.07 |
| 61387 | Hureau Family Trust | Customer Refund | \$39.08 |
| 61388 | Kevin L Baldwin | Customer Refund | \$6.89 |
| 61389 | Dustin M McDonald | Customer Refund | \$14.04 |
| 61390 | Alexander's Contract Services | Contract Services-Meter Read | \$6,901.89 |

| | | | |
|-------|---|------------------------------------|-------------|
| 61391 | American General Life Insurance Company | Disability & Life Insurance | \$3,100.00 |
| 61392 | AnswerNet | Telephone-Answering Service | \$152.11 |
| 61393 | Bart/Riebes Auto Parts | Repair-Trucks | \$7.79 |
| 61394 | Burketts | Office Expense | \$76.03 |
| 61395 | Caltronics Business System | Small Office Equipment | \$343.44 |
| 61396 | CirclePoint | Contract Service-Conservation | \$4,720.14 |
| 61397 | Corelogic Information Solutions Inc | Dues & Subscriptions | \$246.83 |
| 61398 | County of Sacramento | Permit Fees | \$1,591.20 |
| 61399 | Gaynor Telesystems Incorporated | Fixed Assets | \$197.50 |
| 61400 | J4 Systems | Contract Services-Other | \$3,730.00 |
| 61401 | KBA Docusys Inc | Office Expense | \$343.43 |
| 61402 | Office Depot | Office Expense | \$216.32 |
| 61403 | One Print Source & Graphics | Printing | \$29.16 |
| 61404 | Protection One Alarm Monitoring | Office Expense | \$140.00 |
| 61405 | RW Trucking | Contract Services-Miscellaneous | \$3,496.25 |
| 61406 | SureWest Directories | Telephone-Local/Long Distance | \$49.00 |
| 61407 | City of Citrus Heights | Permit Fees | \$1,575.76 |
| 61408 | Corporate Design Group Inc | Contract Services-Other | \$4,510.00 |
| 61409 | Schrecongost Trust | Customer Refund | \$67.80 |
| 61410 | Natalie Cody | Customer Refund | \$7.45 |
| 61411 | Holly/Brian Dismukes | Customer Refund | \$51.10 |
| 61412 | Linda Kahle | Customer Refund | \$5.49 |
| 61413 | Debbie A Snow | Customer Refund | \$9.00 |
| 61414 | Anne-Marie Martin | Customer Refund | \$195.47 |
| 61415 | Aaron/Jamie Tonnesen | Customer Refund | \$8.07 |
| 61416 | THR California LLC | Customer Refund | \$50.60 |
| 61417 | Olga Fedorcea | Customer Refund | \$165.82 |
| 61418 | Matt/Christina Gandara | Customer Refund | \$70.82 |
| 61419 | John/Teresa Soule | Customer Refund | \$46.04 |
| 61420 | Michael J Bailey | Customer Refund | \$63.40 |
| 61421 | West Coast Ref Investors LP | Customer Refund | \$15.12 |
| 61422 | Oleksandr Huzovatyy | Customer Refund | \$8.22 |
| 61423 | Bart/Riebes Auto Parts | Repair-Trucks | \$30.39 |
| 61424 | BSK Associates | Water Analysis | \$1,760.00 |
| 61425 | James Buford | Small Tools | \$66.71 |
| 61426 | Burketts | Office Expense | \$23.68 |
| 61427 | California Surveying & Drafting Supply | Small Tools | \$5.00 |
| 61428 | Corix Water Products, Inc | Material | \$4,082.40 |
| 61429 | Corporate Design Group Inc | Contract Services-Other | \$4,670.00 |
| 61430 | Dawson Oil Company | Gas & Oil | \$867.56 |
| 61431 | Government Finance Officers Association | Dues & Subscriptions | \$160.00 |
| 61432 | Hach Company | Wells Maintenance | \$219.32 |
| 61433 | J4 Systems | Contract Services-Other | \$1,035.00 |
| 61434 | Kaiser Foundation Health Plan, Inc | Health Insurance | \$14,287.76 |
| 61435 | KBA DOCUSYS | Contract Services-Equipment | \$54.47 |
| 61436 | One Print Source & Graphics | Printing | \$144.72 |
| 61437 | Pace Supply Corp | Material | \$137.77 |
| 61438 | Paul N Phillips, Attorney at Law | Legal & Audit | \$4,875.00 |
| 61439 | Pacific Gas & Electric | Utilities | \$28.60 |
| 61440 | River City Fire Equipment | Contract Services-Equipment Repair | \$495.66 |
| 61441 | SHI International Corp | MaintenanceAgreement-Software | \$2,459.08 |
| 61442 | Sophos Solutions | Contract Services-Other | \$5,840.00 |
| 61443 | Titan Workforce LLC | Contract Services-Temporary Labor | \$5,533.88 |
| 61444 | Voyager Fleet Systems Inc | Gas & Oil | \$1,460.51 |
| 61445 | California State Disbursement Unit | Garnishment | \$184.61 |
| 61446 | California State Disbursement Unit | Garnishment | \$87.69 |
| 61447 | Joyce L Harper | Customer Refund | \$134.80 |
| 61448 | Roger/Virginia Reis | Customer Refund | \$167.69 |

| | | | |
|--------------------|---|------------------------------------|----------------------------|
| 61449 | William J Healey | Customer Refund | \$99.65 |
| 61450 | Cecil A/Gloria R Dyer | Customer Refund | \$192.11 |
| 61451 | Richard Myers | Customer Refund | \$60.35 |
| 61452 | Marshall/Peggy Thompson | Customer Refund | \$67.20 |
| 61453 | Sara Abrahamyan | Customer Refund | \$695.48 |
| 61454 | Robert E/Rita J Frasch | Customer Refund | \$108.32 |
| 61455 | Capital Ventures Group LLC | Customer Refund | \$172.50 |
| 61456 | AIA Services, LLC/NDS | Water Conservation-Material/Supply | \$4,649.40 |
| 61457 | Airgas NCN | Supplies-Field | \$320.30 |
| 61458 | AREA Restroom Solutions | Equip Rental-Field | \$114.34 |
| 61459 | BSK Associates | Water Analysis | \$1,184.00 |
| 61460 | Burketts | Office Expense | \$183.59 |
| 61461 | CirclePoint | Contract Services-Conservation | \$3,328.75 |
| 61462 | Sacramento County Utilities | Utilities | \$173.38 |
| 61463 | Future Ford | Repair-Trucks | \$431.84 |
| 61464 | Gaynor Telesystems Incorporated | Fixed Assets | \$470.00 |
| 61465 | David Gordon | Continued Education | \$130.00 |
| 61466 | Integrity Administrators Inc | Health Insurance | \$277.20 |
| 61467 | KASL Consulting Engineers | Contract Services-Engineering | \$6,634.00 |
| 61468 | Kurey & Associates | Contract Services-Engineering | \$2,520.00 |
| 61469 | Liebert Cassidy Whitmore | Legal & Audit | \$357.50 |
| 61470 | Moonlight BPO | Contract Services Bill Print | \$3,721.89 |
| 61471 | Christopher Nichols | Continued Education | \$130.00 |
| 61472 | Pace Supply Corp | Material | \$372.56 |
| 61473 | Petty Cash | Petty Cash | \$155.15 |
| 61474 | Red Wing Shoe Store | Small Tools | \$620.16 |
| 61475 | SHI International Corp | Maintenance Agreement-Software | \$151.62 |
| 61476 | Robin Shockley | Office Expense | \$75.59 |
| 61477 | San Juan Unified School District | Contract Services-Engineering | \$1,458.00 |
| 61478 | A. Teichert & Son, Inc. | Road Base | \$1,652.84 |
| 61479 | The Lincoln National Life Insurance Company | Disability & Life Insurance | \$5,806.42 |
| 61480 | Titan Workforce LLC | Contract Services-Temporary Labor | \$6,176.50 |
| 61481 | Verizon Wireless | Telephone-Wireless | \$1,116.22 |
| 61482 | WaterWise Consulting, Inc | Contract Services-Conservation | \$125.00 |
| 61484 | Corelogic Information Solutions Inc | Dues & Subscriptions | \$245.58 |
| 61485 | US Bank I.M.P.A.C. Government Services | See April Agenda Item CC-9 | \$5,301.85 |
| TOTAL | | | <u>\$353,538.05</u> |
| ACH | PERS 4/17/16PAYROLL | PERS | \$12,911.11 |
| ACH | BOW MARCH 2016 WEB | Bank Fee | \$3,736.24 |
| ACH | POSTAGE 4/6/16 | Postage | \$1,000.00 |
| ACH | 4/15/2016VANCO | Contract Services-Other | \$85.30 |
| ACH | WHAMAY2016 | Health Insurance | \$15,805.94 |
| ACH | VALIC 4/7/16 | Deferred Compensation | \$2,845.00 |
| ACH | VALIC /21/16 | Deferred Compensation | \$2,220.00 |
| ACH | MARCH 2016 FEE | Contract Services-Other | \$330.50 |
| ACH | MARCH 2016 PH | Bank Fee | \$254.25 |
| ACH | MARCH2016 FD | Bank Fee | \$295.74 |
| ACH | PAYROLL4/21/16 | PERS | \$12,678.28 |
| ACH | VOYA 4/7/16 | Deferred Compensation | \$45.00 |
| ACH | VOYA4/21/16 | Deferred Compensation | \$45.00 |
| TOTAL | | | <u>\$52,252.36</u> |
| GRAND TOTAL | | | <u><u>\$405,790.41</u></u> |

May Checks Approved At May Board Meeting

| | | | |
|-------|----------------------------|--------------------------------------|---------------------|
| 61486 | CalSierra Construction Inc | Contract Services-Engineering | \$8,693.05 |
| 61487 | Consolidated | Telephone-Local/Long Distance | \$9,165.29 |
| 61488 | J Crowley Group Inc | Contract Services-Water Conservation | \$9,360.00 |
| 61493 | SMUD | Utilities | \$9,738.88 |
| 61490 | Ernest L Leporini | Contract Services-Engineering | \$9,840.00 |
| 61489 | Lamon Construction CO, INC | Contract Services-Engineering | \$11,551.04 |
| 61491 | R E Smith Contractor Inc | Contract Services-Wells | \$92,049.97 |
| 61492 | San Juan Water District | Purchased Water | \$432,773.19 |
| | | | <u>\$583,171.42</u> |

US BANK - CAL-Card Distributions

April 2016

i/users/ap/CalCard/(current year) -Distribution for monthly payment.xls

| |
|--------------|
| TOTAL |
| BILL |

| #REF! | 11201-05 WIP / TIP Progress- Vehicles | 54210 Tools | 54211 Supplies | 1-54211-00 CIP/Supplies | 54231-02 Main Agree Software | 54241-01 Repair Truck | 54241-02 Repair - Equip/Hardw are | 56200 Office Exp | 56210 Small Office Equipment | 56220 Dues & Subs | 56230 Postage | 56830 C.E. | 56890-01 Office Misc, District Event | 56890-02 Mig Accom | 56890-03 Office Misc, Other |
|-----------|--|----------------|-------------------|----------------------------|------------------------------------|-----------------------------|--|---------------------|------------------------------------|-------------------------|------------------|---------------|---|-----------------------|-----------------------------------|
| Churchill | \$ 181.00 | | | | | | | | | | | 58.00 | | | 123.00 |
| Cutler | \$ 172.54 | | 132.54 | | | | | | | | | 40.00 | | | |
| Dains | \$ - | | | | | | | | | | | | | | |
| Dietrich | \$ - | | | | | | | | | | | | | | |
| Evans | \$ 2,183.96 | 430.14 | | 362.10 | | 450.00 | 527.37 | 149.72 | | | | 60.00 | 160.11 | 44.52 | |
| Gordon | \$ - | | | | | | | | | 14.99 | | | | | |
| Hensley | \$ 357.62 | 315.00 | 27.63 | | | | | | | | | | | | |
| Riehle | \$ - | | | | | | | | | | | | | | |
| Sheehan | \$ - | | | | | | | | | | | | | | |
| Smoot | \$ 1,012.28 | | | | | | | | | | 109.65 | 383.98 | | 43.65 | 475.00 |
| Straus | \$ 1,394.45 | 745.14 | 160.17 | 362.10 | 250.00 | 19.99 | 527.37 | 149.72 | - | 14.99 | 109.65 | 541.98 | 160.11 | 88.17 | 598.00 |
| | \$ 5,301.85 | 1,124.46 | 1,124.46 | 362.10 | 250.00 | 469.99 | 527.37 | 149.72 | - | 14.99 | 109.65 | 541.98 | 160.11 | 88.17 | 598.00 |

2016

V#: _____
Date: 4/22/16

Citrus Heights Water District
2016 Director Training Courses/Seminars/Conferences
as of 5/3/2016

| Date | Days | Topic | Sponsor | Location | Attendee | Total Expenses | Registration | Hotel | Air/Travel | Car rental | Meals | Parking/Taxi/phone |
|----------|------|------------------------|------------|-----------------|-------------|----------------|--------------|--------|------------|------------|-------|--------------------|
| 02/04/16 | 1 | Water Workshop 101 | AWWA CA/NV | West Sacramento | Ray Riehle | 225.00 | 225.00 | | | | | |
| 05/02/16 | 2 | ACWA Spring Conference | ACWA | Monterey | Al Dains | 1,292.00 | 695.00 | 597.00 | | | | |
| | | | | | | 0.00 | | | | | | |
| | | | | | | 0.00 | | | | | | |
| | | | | | | 0.00 | | | | | | |
| | | | | | | 0.00 | | | | | | |
| | | | | | Grand Total | 1,517.00 | | | | | | |

I:\users\Continued Ed\Continued Ed-2009.xls

Citrus Heights Water District
 2016 Officer Training Courses/Seminars/Conferences
 as of 5/3/2016

I:\users\Continued Ed\Continued Ed-2009.xls

| Date | Days | Topic | Sponsor | Location | Attendee | Total Expenses | Registration | Hotel | Air/Travel | Car rental | Meals | Parking/Taxi/phone |
|----------|------|-------------------|------------|------------|--------------------|-----------------|--------------|--------|------------|------------|-------|--------------------|
| 03/21/16 | 3 | Spring Conference | AWWA CA/NV | Sacramento | Hilary Straus | 445.00 | 445.00 | | | | | |
| 03/21/16 | 3 | Spring Conference | AWWA CA/NV | Sacramento | Robert Churchill | 445.00 | 445.00 | | | | | |
| 03/21/16 | 3 | Spring Conference | AWWA CA/NV | Sacramento | David Gordon | 445.00 | 445.00 | | | | | |
| 05/01/16 | 2 | Spring Conference | ACWA | Monterey | Robert Churchill | 1,491.00 | 695.00 | 796.00 | | | | |
| 05/01/16 | 2 | Spring Conference | ACWA | Monterey | Hilary Straus | 1,491.00 | 695.00 | 796.00 | | | | |
| | | | | | | 0.00 | | | | | | |
| | | | | | | 0.00 | | | | | | |
| | | | | | | 0.00 | | | | | | |
| | | | | | | 0.00 | | | | | | |
| | | | | | | 0.00 | | | | | | |
| | | | | | | 0.00 | | | | | | |
| | | | | | | 0.00 | | | | | | |
| | | | | | | 0.00 | | | | | | |
| | | | | | Grand Total | 4,317.00 | | | | | | |

CITRUS HEIGHTS WATER DISTRICT

DISTRICT STAFF REPORT TO BOARD OF DIRECTORS MAY 10, 2016 REGULAR MEETING

SUBJECT : ADMINISTRATION BUILDING IMPROVEMENTS PROJECT
STATUS : Information Item – Consent Calendar
REPORT DATE : April 30, 2016
PREPARED BY : Robert A. Churchill, General Manager

OBJECTIVE:

Receive information on adding an office to the Administration Building.

BACKGROUND AND ANALYSIS:

Upon issuance of a building permit from the City of Citrus Heights on April 15, 2016, construction of the Administration Building office addition by Kaler-Dobler Construction began. Construction is well underway with the following items completed at the time of this report:

- Concrete footing and slab.
- Exterior wall framing and window casings.
- Rough electrical.
- Wall Insulation (note: Ceiling insulation was completed with the prior project).

Preparation and installation of interior drywall and exterior stucco are likely to be well underway or completed by the Board Meeting date followed thereafter by heating/air conditioning ductwork and T-bar ceiling.

Furniture requirements were developed in consultation with Corporate Design Group and orders placed.

The target date for completion is June 15, 2016.

CITRUS HEIGHTS WATER DISTRICT

DISTRICT STAFF REPORT TO BOARD OF DIRECTORS MAY 10, 2016 REGULAR MEETING

SUBJECT : AUTHORIZATION FOR ACCOUNTING SUPERVISOR TO ATTEND
GOVERNMENT FINANCE OFFICERS ASSOCIATION (GFOA) ANNUAL
CONFERENCE

STATUS : Action Item

REPORT DATE : April 29, 2016

PREPARED BY : Hilary M. Straus, Assistant General Manager

OBJECTIVE:

Consider authorizing the Accounting Supervisor/Deputy Treasurer to attend the GFOA Conference, and authorizing the General Manager to approve actual and necessary expense reimbursements related to conference attendance.

BACKGROUND AND ANALYSIS:

A goal that the District has for its employees is that staff remain current in their subject matter field of expertise (e.g., finance/accounting), and in general, in professional areas involving technical issues, applicable policies, laws and practices, leadership/organizational skills and building and maintain professional networks. Another District human resource goal is to offer opportunities that will grow and develop employees as they aspire to move up the professional ladder and/or for succession planning.

To those ends, funding has been included in the 2016 Operating Budget for the Accounting Supervisor to attend an off-site conference/training opportunity within the finance and accounting field. This year, scheduling wise, attendance at the GFOA conference versus the California Society of Municipal Finance Officers Association (CSMFO) Annual Conference fits better with Accounting Supervisor Sohal's work schedule, and the GFOA Conference, which is scheduled for May 22-25, 2016, works well for the District, as it is occurring in a relatively less impacted time with regard to the finance/accounting annual workload, not conflicting with special projects such as the update of the rate model, preparation of the budget and audit.

This year's GFOA conference is located in Toronto, Ontario, Canada. Per District Policy 2060, "Educational and Training Functions," which accompanies this staff report, any conference attendance occurring outside the west coast (California, Nevada, Oregon or Washington) requires Board approval, and any "actual and necessary expenses while in attendance at [these] functions" outside the west coast "shall require formal approval of the Board of Directors." Notwithstanding, there is no policy provision that prohibits the Board from delegating the expense reimbursement authority to the General Manager should the Board wish to do so, and that authorization is included in the recommended action below.

Estimated conference expenses include: Conference Registration \$360 (normal conference registration is \$925, but with a first-time attendee scholarship, the registration fee is reduced by \$525), \$500 for airfare and \$150 for car rental. Some, but not, all meals will be included in the conference. For those meals that are not, there will be an additional reimbursable cost. Per District Policy 2060, meals that are expensed are reimbursed at: Breakfast: \$20/day; Lunch: \$25/day; Dinner: \$45/day. As AS Sohal has family in the Toronto area and is offering to stay with them, several hundred dollars in hotel expenses to the District

will be eliminated. With the conference's downtown Toronto location, daily parking expenses are anticipated. With AS Sohal's first time conference attendance scholarship (already approved by GFOA), total conference expenses are estimated to be below \$1,500.

Some of the key GFOA breakout sessions include (Note—Due to overlapping offerings and scheduling constraints, AS Supervisor Sohal won't be able to attend all of these sessions): Pension Funds and Infrastructure, The Value of Transparency, Coping with Unfunded Mandates—When the “Buck” Gets Passed to You, The Bond Market: A Legislative/Regulatory Update, Water: is Blue Gold the “New Normal?”, Running a Tight Ship: Making the Internal Audit Work for You, Service-Level Agreements for IT, Using Cash-Flow Forecasting to Support Fiscal Sustainability, Capital Budgeting for Short-Term Assets, The Accounting and Auditing Year in Review, Accurate Pension Forecasting, Taking it to the Next Level: GFOA's Certification Program, Next Generation of Finance, Putting it All Together: Preparing the Financial Statements, Getting Out Front—Stopping Fraud Before it Starts, The Future is Now: Implementing GASB Guidance on Pensions and OPEB (Other Post Employment Benefits), In it for the Long Haul: Accounting for Capital Assets, Reaching for the Sky: Internal Control over Cloud/Outsourced Functions, Accurate and Effective Forecasting, Something for Everyone: Adjusting to the OMB's “Super Circular,” and Budgeting and Funding Infrastructure Maintenance.

One of the keynote speakers is Bruce Tulgan, founder of RainMakerThinking, and is an internationally recognized expert in leadership and performance management in the workplace.

If approved for attendance, AS Sohal will provide the Board and management staff with a report after attending the conference.

RECOMMENDATION:

Authorize the Accounting Supervisor's attendance at GFOA Conference, and authorize the General Manager to approve actual and necessary expense reimbursements related to conference attendance.

ACTION:

Moved by Director _____, Seconded by Director _____, Carried _____

CITRUS HEIGHTS WATER DISTRICT
POLICIES AND PROCEDURES MANUAL

POLICY TYPE : BOARD OF DIRECTORS AND OFFICERS
POLICY TITLE : EDUCATIONAL AND TRAINING FUNCTIONS
POLICY NUMBER : 2060
DATE ADOPTED : MARCH 7, 1995
DATE AMENDED : JANUARY 7, 2003

2060.00 EDUCATIONAL AND TRAINING FUNCTIONS

The Board of Directors supports participation by members of the Board of Directors, Officers, and Staff at educational and training functions of national, state, or local significance that either directly relate to the purposes, goals and objectives of the District or that contribute to a better understanding of water and management issues relevant to District operations. There is no limit as to the number of Directors and Officers attending a particular educational or training function when it is apparent that their attendance is beneficial to the District.

Educational and training functions typically include meetings, seminars, facility tours, and conferences related to District purposes and operations including, but not limited to, those presented under the auspices of the following organizations:

- American Water Works Association (AWWA)
- American Society of Civil Engineers (ASCE)
- Association of California Water Agencies (ACWA)
- ACWA Joint Powers Insurance Authority (ACWA-JPIA)
- California Special District Association (CSDA) including local Chapters
- Regional Water Authority (RWA)
- Sacramento Area Water Works Association (SAWWA)
- Sacramento Groundwater Authority (SGA)
- Sacramento Water Forum (Water Forum)

2060.10 ATTENDANCE BY DIRECTORS

Members of the Board of Directors are authorized to attend functions of their choosing except that reimbursement for actual and necessary expenses while in attendance at functions outside of California, Nevada, Oregon or Washington shall require formal approval from the Board of Directors.

A Director shall not attend a conference or training event for which there is an expense to the District if it occurs after they have announced their pending resignation or have not filed for re-election, or if it occurs after an election in which it has been determined that they will not retain their seat on the Board of Directors except as formally authorized by action of the Board of Directors.

2060.15 ATTENDANCE BY OFFICERS AND THE GENERAL MANAGER

Officers and the General Manager are authorized to attend functions of their choosing except that reimbursement for actual and necessary expenses while in attendance at functions outside of California, Nevada, Oregon or Washington shall require formal approval from the Board of Directors. Expenses per person in excess of \$1,750.00 per function and aggregately \$6,000.00 per calendar year shall require formal approval from the Board of Directors.

2060.20 ATTENDANCE BY STAFF

The General Manager is authorized to approve attendance of staff at educational and training functions in California, Nevada, Oregon and Washington that directly relate to District operations except that attendance at functions with a direct cost exceeding \$1,500.00 per person shall require formal approval from the Board of Directors.

2060.30 COMPENSATED MEETING DAY

Directors shall be entitled to receive meeting day compensation in accordance with Compensation and Reimbursement Policy 2040 for each day's or partial day's attendance at an authorized educational or training function plus one day for travel if necessary.

2060.50 EXPENSES

The District shall pay for actual and necessary expenses for attendance at education and training functions.

2060.51 Function Expenses

The District will generally pay fees for registration and attendance at educational and training functions in advance for its representative(s).

2060.52 Travel Expenses

Travel expenses shall be allowed based upon the actual mode of travel. Travel arrangements may be made by the individual or by the District.

Travel by personal vehicle is permitted within California and Nevada and shall be reimbursed at the current expense rate authorized under Internal Revenue Service regulations per actual mile driven, not to exceed the cost of an unrestricted round-trip coach air fare plus associated ground transportation and parking expenses. Travel by personal vehicle is permitted and shall be reimbursed not to exceed the cost of an unrestricted round-trip coach airfare plus associated ground transportation and parking expenses.

Travel by air, train, or bus is permitted and shall not exceed or be reimbursed beyond the cost of an unrestricted round-trip coach air fare plus associated ground transportation and parking expenses.

2060.53 Lodging Expenses

Actual lodging expenses will be paid or reimbursed at an amount not to exceed the highest published conference rates for accommodations. Lodging arrangements may be made by the individual or by the District.

2060.54 Meal Expenses

Meal expenses necessary for function attendance and travel shall be reimbursed at actual cost subject to the following limitations:

| | |
|-----------|---------|
| Breakfast | \$15.00 |
| Lunch | \$20.00 |
| Dinner | \$35.00 |

At the discretion of the Director, the dollar limits for individual meals as shown above may be exceeded, provided that a daily total of \$70.00 for all meals is not exceeded. Meals paid directly by the District as an accompaniment to registration may exceed the basic meal allowances.

Receipts shall be required for meal expenses unless a receipt is not available (e.g., meal eaten with another party, other party kept the receipt). In cases where a receipt is not available, the Director, Officer or employee shall provide reasonable documentation of the expense including the reason why a receipt was not available.

2060.55 Other Expenses

Other actual and necessary expenses, including but not limited to such items as car rental, taxi or bus fares, gratuities, parking, telephone calls, and facsimile transmissions will be reimbursed at cost. Reimbursement for expenditures of other expenses in excess of \$20.00 requires a receipt. In cases where a receipt is not available (e.g., taxi ride), the Director, Officer or employee shall provide reasonable documentation of the expense including the reason why a receipt was not available.

2060.56 Spouse/Companion Expenses

Spouse and/or companions may accompany District representatives to educational and training functions at the sole and total expense of the spouse/companion(s). It is incumbent upon the Director, Officer or employee to document those additional expenses that may accrue due to a spouse and/or companion, and to deduct said expenses from any expenses being submitted to the District for reimbursement or reconciliation.

2060.57 Credit Cards

Directors and Officers are authorized to use a District credit card(s) for transaction of District business. A monthly report of such expenditures shall be included with the monthly financial reports presented to the Board of Directors at their regular meeting.

A District credit card(s) shall not be used for personal expenses.

2060.58 Expense Reconciliation

Upon the conclusion of an educational or training event for which expenses have been

incurred, all expenses shall be documented and reconciled on the District's "Conference/Meeting Expense Reconciliation" form (see Attachment 2060.A1).

2060.59 Reporting

An annual report shall be prepared by the Treasurer quantifying attendance and expenses at training and educational functions for members of the Board of Directors and District Officers.

2060.70 DIRECTORS' REPORTS

Upon returning from seminars, workshops, conferences, etc., where expenses are reimbursed by the District, Directors and Officers will either prepare a written report for distribution to the Board of Directors, or make a verbal report during the next regular meeting of the Board. Said report shall detail what was learned at the session(s) that will be of benefit to the District. Materials from the session(s) may be delivered to the District office to be included in the District library for future use and reference by Directors, Officers and staff.

CITRUS HEIGHTS WATER DISTRICT

DISTRICT STAFF REPORT TO BOARD OF DIRECTORS MAY 10, 2016 REGULAR MEETING

SUBJECT : RAMIREZ CLAIM FOR DAMAGES
 STATUS : Action Item – Consent Calendar
 REPORT DATE : May 2, 2016
 PREPARED BY : David M. Gordon, Operations Manager
 Lisa A. Smoot, Management Services Supervisor

OBJECTIVE:

Consider a claim for property damage from Salvador Ramirez.

BACKGROUND AND ANALYSIS:

Mr. Salvador Ramirez is requesting reimbursement for excavation and/or surface restoration at 7850/52 Sampolo Court.

OM Gordon has investigated the claim and his reports regarding the claim are attached including photographs of the exposed pipe showing a hole the same size as the tool being used by the claimant. The following facts and observations are drawn from OM Gordon's investigation:

1. Saturday, March 26, 2016; Customer's representative called to report a leak on their property at the water meter. The District's after-hours standby staff and the customer's representative determined that the leak could wait until Monday (regular District business hours) for a District representative to perform a field investigation.
2. Monday, March 28, 2016; A field investigation of the leak, by the District, could not be concluded due to the inability to access shut-off valves on the property (i.e. sprinklers). The field investigation did suggest that the leak was most likely on the Private side of the water meter due to the water meter continuing to show flow similar to the amount of water leaking onto the sidewalk.
3. Tuesday, April 5, 2016; A follow-up investigation of the leak, by the District, was performed at the property. The investigation was inconclusive due to oversaturation of the soil. The District notified USA north in order to perform a larger scale leak investigation at the property.
4. Tuesday, April 5, 2016; Customer's representative called the District's after-hours standby staff and told them that there is a leak coming from the water meter box near the driveway. The customer's representative then said that it is not seriously bad and can wait for the morning to have someone check it out.
5. Wednesday, April 6, 2016; District staff received a phone call from the customer's representative stating that they had found the leak on the District's facilities. District staff arrived at the property whereby significant excavation was performed in violation of California Government Code 4216.
 - a. No customer or customer representative was on site.
 - b. The District crews pumped out the water that filled the excavation at the driveway location.
 - c. A small piece of the Asbestos Cement Pipe was missing from the top of the 6-inch water main thus causing a water main leak.
 - d. The District crews took photos of the water main, a digging pick found in the excavation, and the excessive digging that occurred at the water meter box which is approximately 40-feet

- away from the water main leak.
- e. The District crews installed a water main repair band on the water main to stop the leak. The excavation at the water main repair was backfilled to District Specifications by the District in order to avoid a public safety hazard around the District's facilities.
 - f. District staff also noted that the sprinkler line, shown in the photos, was cut by the customer and/or customer representative in order to search for the assumed leak.

Citrus Heights Water District repaired the water main at 7850/52 Sampolo Court on Wednesday, April 6, 2016. An investigation of the water main leak was determined to be caused by excessive force due to the homeowner exposing the water main. Failure on an Asbestos Cement Pipe water main with a pinhole leak, like this leak, has never been observed by District staff. District staff believes that the claim lacks merit and recommends denying it.

RECOMMENDATION:

Deny the claim from Salvador Ramirez for property damage in an unspecified amount and forward it to the District's insurance carrier, ACWA-JPIA.

ACTION:

Moved by Director _____, Seconded by Director _____, Carried _____

ATTACHMENT 1
Investigation Reports

Claim Form

RECEIVED

APR 25 2016

(A claim shall be presented by the claimant or by a person acting on his behalf.)

Citrus Heights Water Dist.

NAME OF DISTRICT:

1 Claimant name, address (mailing address if different), phone number, social security number, e-mail address, and date of birth.
Effective January 1, 2010, the Medicare Secondary Payer Act (Federal Law) requires the District/Agency to report all claims involving payments for bodily injury and/or medical treatments to Medicare. As such, if you are seeking medical damages we must have both your Social Security Number and your date of birth.

Name: Salvador Ramirez

Address(es): 7850 Sampolo Ct Citrus Hts
CA 95610

Phone Number: (916) 200-5085

Social Security No.: 626-09-0074

Date of Birth: 1/28/1971

E-mail:

2 List name, address, and phone number of any witnesses.

Name: Stacy Miller

Address: 7007 Jamestree Way Citrus Hts, CA 95610

Phone Number: (916) 671-0337

3 List the date, time, place, and other circumstances of the occurrence or transaction, which gave rise to the claim asserted.

Date: 4/4/2016 Time: 7:00 am Place: 7850 Sampolo Ct Citrus Hts CA 95610

Tell What Happened (give complete information): We noticed a leak near our sidewalk that was continuing to get worse. We contacted CHWD to come out and look at the leak, crew came out and stated that the pipe that was leaking was not their responsibility. We, the took into our matter and hired a plumber, plumber stated the leak was from CHWD. We then contacted CHWD again they came and fixed pipe but the rest of damage properly

NOTE: Attach any photographs you may have regarding this claim. was not.

4 Give a general description of the indebtedness, obligation, injury, damage, or loss incurred so far as it may be known at the time of presentation of the claim.

A lot of damages have been made to my drive way and both front lawns attempting to look for damage pipe.

5 Give the name or names of the public employee or employees causing the injury, damage, or loss, if known.

Name of public employees are unknown.

6 The amount claimed if it totals less than ten thousand dollars (\$10,000) as of the date of presentation of the claim, including the estimated amount of any prospective injury, damage or loss, insofar as it may be known at the time of the presentation of the claim, together with the basis of computation of the amount claimed. If the amount claimed exceeds ten thousand dollars (\$10,000), no dollar amount shall be included in the claim. However, it shall indicate whether the claim would be a limited civil case.

Date: 4/13/16 Time: 5:00 p.m. Signature: Salvador Ramirez

ANSWER ALL QUESTIONS. OMITTING INFORMATION COULD MAKE YOUR CLAIM LEGALLY INSUFFICIENT!

Citrus Heights Water District

Request: 1000350834 Check for a leak on a property

Address: 7850 SAMPOLO CT

Dispatched To: SPIERS, NICHOLAS
 Date Dispatched: 3/28/2016 9:45:00 AM
 Map Page: 047

Initiated By: CHAMBERS, BRADY
 Date Initiated: 3/28/2016 9:43:23 AM
 Priority: Medium

Details: Customer reporting leak at the street please check.

Location:

| First Name | Last Name | Address | City | Zip | Home Phone | Work Phone |
|-----------------|-----------|--------------------|----------------|-----------|------------------|------------------|
| SALVADOR R/SARA | RAMIREZ | 7850/52 SAMPOLO CT | CITRUS HEIGHTS | 956103939 | 0000000000000000 | 0000000000000000 |

| Customer Account | Customer Comments | Caller Problem Details | Date/Time of Call |
|------------------|-------------------|---|----------------------|
| 08033 | | Customer reporting leak at the street please check. | 3/28/2016 9:43:23 AM |

| Custom Field Names | Custom Field Value |
|--------------------|--|
| METER NUMBER | 49678735 |
| REMOTE ID | 49678735 |
| METER LOCATION | 12' W FROM E PL 8'.5" FROM BKW 36'.5" FROM NE CNR OF HOUSE |
| METER TYPE | NET10_1 Neptune T-10 Disc |
| LAST READ | 3516 |
| LAST READ DATE | 2/8/2016 12:00:00 AM |
| SO NUMBER | SORD00000350834 |
| CURRENT READ | |
| CUR READ DATE | |

Comments: Customer reporting leak at the street please check.

END COGSDALE NOTES

By SPIERS, NICHOLAS: 3/28/2016 10:21:15 AM *MWD DA?*

pvt leak. talked to customer. customer did not speak very good English..... did my best to talk to him?



NICK - LEAK INVESTIGATION FOR SERVICE CALL REPORT - 3/26/2016 SAIDRA

Tim Cutler

From: support@usan.org
Sent: Tuesday, April 05, 2016 9:42 AM
To: Tim Cutler
Subject: USAN 2016/04/05 #00000 0166746-000 NORM NEW

TUESDAY

00000 USAN 04/05/16 09:41:38 0166746 NORMAL NOTICE

Message Number: 0166746 Received by USAN at 09:37 on 04/05/16 by RMO

Work Begins: 04/07/16 at 10:00 Notice: 020 hrs Priority: 2
Night Work: N Weekend Work: N

Expires: 05/03/16 at 23:59 Update By: 04/29/16 at 16:59

Caller: **TIM CUTLER**
Company: **CITRUS HEIGHTS WATER DISTRICT**
Address: 6230 SYLVAN RD, CITRUS HEIGHTS
City: CITRUS HEIGHTS State: CA Zip: 95610
Business Tel: 916-725-6873 Fax: 916-725-0345
Email Address: TCUTLER@CHWD.ORG

Nature of Work: **EXC FOR LEAK INVEST**

Done for: SAME Explosives: N
Foreman: CALLER
Field Tel: Cell Tel: 916-735-7720
Area Premarked: Y Premark Method: WHITE PAINT
Permit Type: CITY Number: BLANKET
Vac / Pwr Equip Use In The Approx Location Of Member Facilities Requested: Y Excavation Enters Into Street Or Sidewalk Area: Y

Location:
Street Address: **7850 SAMPOLO CT**
Cross Street: JAMESTREE WAY

*Follow-up visit per Nick:
* Nick stated meter stopped.
Marked out for USA - Leak investigation*

WRK FRT & W/SI/O PROP EXT 20' IN & 10' INTO ST

Place: CITRUS HEIGHTS County: SACRAMENTO State: CA

Long/Lat Long: -121.274345 Lat: 38.692696 Long: -121.273275 Lat: 38.693659

Sent to:
CITWTR = CITRUS HEIGHTS WTR DIST CTYGSD = CITY OF CITRUS HEIGHTS-G
COMSAC = COMCAST-SACRAMENTO CCICOM = CONSOLIDATED COMM
NDPTST = NDP - TEST ONLY PACBEL = PACIFIC BELL
PGESAC = PGE DISTR SACRAMENTO COSAC4 = SAC AREA SEWER DISTRICT
SACSU2 = SAC. SUBURBAN WTR DIST 2 SMUDSO = SMUD
XOCOM3 = XO COMM SVCS DBA XO COMM



CITRUS HEIGHTS WATER DISTRICT

MON. *3-28-16 @ 10:21am **SERVICE CALL REPORT**
NICK SR. - Private LEAK

Date of Incident: 4-5-16 : Tuesday Call Received: 9:25 AM / PM
Customer's Name: Jorge
Telephone No: Cell: 916-821-9719 Home: _____
Address Of Incident: 7850-52 San Polo Ct.

Nature of the Problem/Concern:
05APR16 2124 OPR dispatch MSG 1829
L OPR TO
O: RICK O/C
FROM JORGE EEREP
PHONE: (916)821-9719 EXT CELL
ADDRESS:
7850 & 7852 SAN POLO COURT, CITRUS HEIGHTS, CA
MESSAGE:
HAS A LEAK FROM THE MAIN PIPE. PLEASE CALL.

- In Break/Leak
- en/Leaking
- Flooding
- n/Leaking
- ON
- OFF
- e
- near meter box

Additional Comments:
Customer called said there is leak coming from meter box near driveway. Said not serious bad can wait for morning to have some one check it out

DOCUMENTATION
04/05/2016 21:25 DISPATCH CLD RICK O/C
CELL & DLVD MSG

- Address
- Repair Required
- Private Water Leak Repair Required
- Emergency Main Repair
- Emergency Service Replacement
- Turned Water Service ON
- Turned Water Service OFF
- Telephone/Inform Customer
- Instructed Customer To Call Plumber
- Referred To Supervisor
- Re-Establishing Your Water Service
- Other
- OUT OF CHWD Boundaries

Additional Comments:
no action taken

Wes.
4-5-2016
9:25pm
Call- Rick
Receive call
from service

BUYORD REPAIRED MAIN LEAK
WED 4-6-16

Salvador -
* Spoke to Jorge via phone 4/12/16
re: District bill & no restrictions.

Begin Service Call: _____ Complete Service Call: _____
Employee: Rick Quinn Approved by: _____
Approved: Yes No Total Hours: _____

08033
✓

****SERVICE CALL REPORT****



Date of Incident: March 26 : 2016 Call Received: 4:48 AM / PM

Customer's Name: Salvador Ramirez Home: _____

Telephone No: Cell: 200-5085

Address Of Incident: 7850 Sampolo Ct.

Nature of the Problem/Concern:

26MAR16 1648 OPR vanessa MSG 1809
OPR TO
RYON: 4/R RYON
FROM JOSE HERNANDEZ/ SALVADOR RAMIREZ
PHONE: (916)200-5085 EXT:
ADDRESS:
850 SAN POLO CT. C.H. 95610
MESSAGE:
LEAK AND WATER COMING OUT FROM THE
WATER METER AND HIS HOUSE.
DOCUMENTATION

- Leak/Leak
- Leaking
- Clogging
- Leaking
- No Leak
- Other

| |
|-------------------------------------|
| <input checked="" type="checkbox"/> |
| <input type="checkbox"/> |
| <input type="checkbox"/> |
| <input type="checkbox"/> |
| <input type="checkbox"/> |
| <input type="checkbox"/> |
| <input type="checkbox"/> |
| <input type="checkbox"/> |
| <input type="checkbox"/> |

Additional Comments:

3/26/2016 16:48 VANESSA DLVD RYON

Visit To Reported Address

Water Main Repair Required

Private Water Leak Repair Required

Emergency Main Repair

Emergency Service Replacement

Turned Water Service ON

Turned Water Service OFF

Telephone/Inform Customer

Instructed Customer To Call Plumber

Referred To Supervisor

Re-Establishing Your Water Service

Other

OUT Of CHWD Boundaries

| |
|-------------------------------------|
| <input type="checkbox"/> |
| <input checked="" type="checkbox"/> |
| <input type="checkbox"/> |
| <input type="checkbox"/> |
| <input type="checkbox"/> |
| <input type="checkbox"/> |
| <input type="checkbox"/> |
| <input type="checkbox"/> |
| <input type="checkbox"/> |
| <input type="checkbox"/> |
| <input checked="" type="checkbox"/> |

Additional Comments:

Called customer back, it was hard to understand him but he said he has a **small leak by meter.**

PRIVATE LEAK PER METER

Begin Service Call: _____ Complete Service Call: _____

Employee: Ryan Bidnic Approved by: _____

Approved: Yes No Total Hours: 0

JARRE CALLED WEDNESDAY 4/6/2016 STATING HE FOUND LEAK AT WATER MAIN. SENT CREW TO INVESTIGATE.

Citrus Heights Water District

Work Order: 77134 MAIN REPAIR
Address: 7850-52 SAMPOLO CT

| WO Initiated: | W/O Start - Finish: | Requested: | Submitted: | Project: | Supervisor: | Priority/Status: |
|---------------------------------------|----------------------|------------|-------------|----------|-------------|------------------|
| 4/6/2016 11:25:54 AM BUFORD, JAMES | 4/6/2016 11:30:54 AM | | CUTLER, TIM | | CUTLER, TIM | Medium Open |

Account Num: OPERATING

Map Page: 047

Labor:

| Date | Hours | Employee | Task Name | Trans. Date | Total |
|--------------------------|-------|----------------|-----------|----------------------|-----------------|
| 4/6/2016 12:00:00 AM | 5.50 | RIDNER, RYON | WORK | 4/6/2016 11:41:02 AM | \$214.24 |
| 4/6/2016 12:00:00 AM | 5.50 | FLINK, JARRETT | WORK | 4/6/2016 11:41:03 AM | \$256.82 |
| 4/6/2016 12:00:00 AM | 5.50 | BUFORD, JAMES | WORK | 4/6/2016 11:41:03 AM | \$256.82 |
| Total Labor Cost: | | | | | \$727.88 |

Material:

| Description | Material Source | Task Name | Qty | Unit Cost | Total |
|------------------------------|-----------------|-----------|-------|-----------|-----------------|
| FCRB 07.05-7.45 x 07.5" WIDE | MAIN | WORK | 1.00 | \$52.92 | \$52.92 |
| RM .75 AB ROCK CU YD | MAIN | WORK | 4.00 | \$35.76 | \$143.04 |
| RM TEMP CUTBACK | MAIN | WORK | 45.00 | \$1.35 | \$60.75 |
| RM PLASTER SAND | MAIN | WORK | 1.00 | \$44.18 | \$44.18 |
| Total Material Cost: | | | | | \$300.89 |

Equipment:

| Description | Equip Source | Hours | Units | Unit Cost | Total |
|---------------------------------------|--------------|-------|-------|-----------|-----------------|
| 2012 FX30 Ditchwitch Vacuum Excavator | Inventory | 5.50 | 1.00 | \$82.50 | \$82.50 |
| 2013 Ford F550 | Inventory | 5.50 | 1.00 | \$196.24 | \$196.24 |
| 2013 Case 590SN Backhoe | Inventory | 5.50 | 1.00 | \$302.01 | \$302.01 |
| 2014 (model 2015) Ford Dump Truck | Inventory | 5.50 | 1.00 | \$306.30 | \$306.30 |
| Total Equipment Cost: | | | | | \$887.04 |

Total Work Order Cost: \$1,915.81

Custom Fields:

| Custom Field Names | Custom Field Value |
|--------------------|--------------------|
| SAMPLE NEEDED | NO |
| TYPE OF MAIN | AC |
| CAUSE1 | DAMAGE |
| MAIN SIZE | 6" |
| EST WATER LOSS | 2000 |

WO Tasks:

| Order | Task Description | Name | Task Actual Start Date | Task Status | Task Comments |
|-------|--------------------------|---------------|------------------------|-------------|---------------|
| 1 | USA_LOCATE | CUTLER, TIM | | CURRENT | |
| 2 | PHOTOS | BUFORD, JAMES | 4/6/2016 11:32:10 AM | COMPLETE | |
| 3 | WORK | BUFORD, JAMES | 4/6/2016 11:32:39 AM | COMPLETE | |
| 4 | LANDSCAPE | BUFORD, JAMES | 4/6/2016 11:48:32 AM | COMPLETE | |
| 5 | CONCRETE | CUTLER, TIM | | PENDING | |
| 6 | PAVING | | | PENDING | |
| 7 | INSPECTION | | | PENDING | |
| 8 | GIS_MAPPING_UPDATE | SWING, BOREY | | PENDING | |
| 9 | FINAL CLOSED WORK ORDERS | EVANS, ROBYN | | PENDING | |

Comments:

Instructions:

ATTACHMENT 2

Photos



2016. 4. 6 8:27





2016. 4. 6 8:05



2016. 4. 6 8:05



2016. 4. 6 8:05

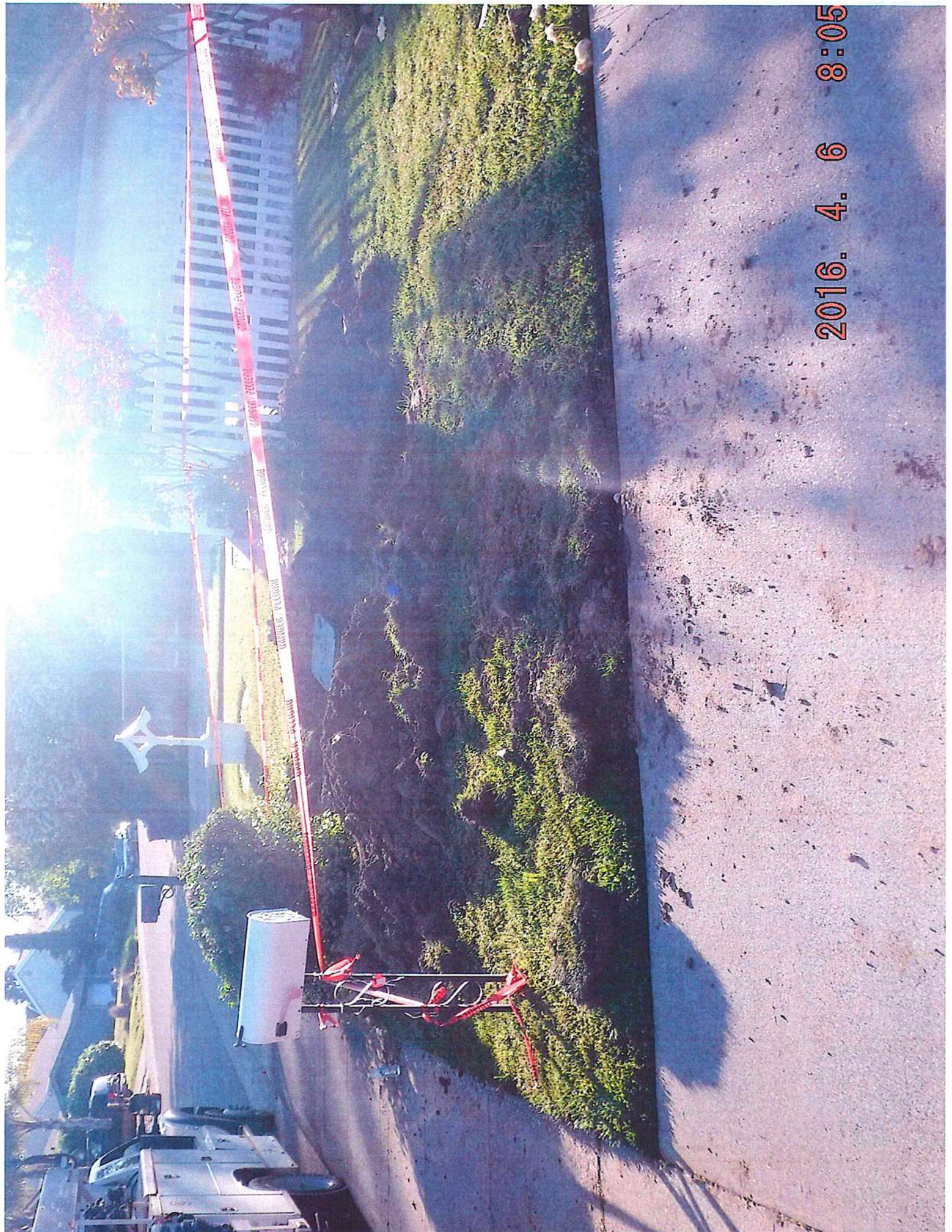

2016. 4. 6 8:05



2016. 4. 6 8:05



2016. 4. 6 8:27

ATTACHMENT 3

California Government Code 4216

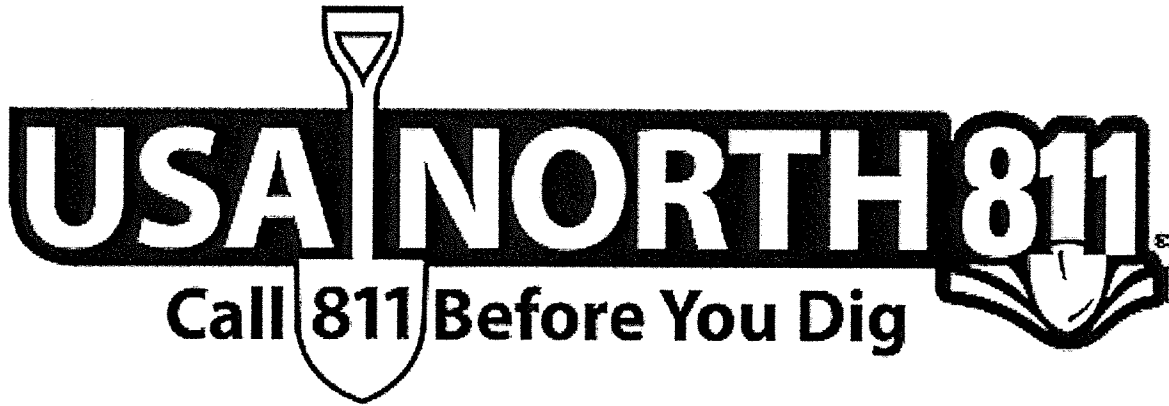

California Excavation Law



Table of Contents

- **California Gov. Code 4216 - Page 3**
- **CalOSHA Title 8, Section 1541 - Page 23**

California Government Code 4216



4216. As used in this article the following definitions apply:

(a) "Approximate location of subsurface installations" means a strip of land not more than 24 inches on either side of the exterior surface of the subsurface installation.

"Approximate location" does not mean depth.

(b) "Excavation" means any operation in which earth, rock, or other material in the ground is moved, removed, or otherwise displaced by means of tools, equipment, or explosives in any of the following ways: grading, trenching, digging, ditching, drilling, augering, tunneling, scraping, cable or pipe plowing and driving, or any other way.

(c) Except as provided in Section 4216.8, "excavator" means any person, firm, contractor or subcontractor, owner, operator, utility, association, corporation, partnership, business trust, public agency, or other entity that, with their, or his or her, own employees or equipment performs any excavation.

(d) "Emergency" means a sudden, unexpected occurrence, involving a clear and imminent danger, demanding immediate action to prevent or mitigate loss of, or damage to, life, health,



property, or essential public services. "Unexpected occurrence" includes, but is not limited to, fires, floods, earthquakes or other soil or geologic movements, riots, accidents, damage to a subsurface installation requiring immediate repair, or sabotage.

(e) "High priority subsurface installation" means high-pressure natural gas pipelines with normal operating pressures greater than 415kPA gauge (60psig), petroleum pipelines, pressurized sewage pipelines, high-voltage electric supply lines, conductors, or cables that have a potential to ground of greater than or equal to 60kv, or hazardous materials pipelines that are potentially hazardous to workers or the public if damaged.

(f) "Inquiry identification number" means the number that is provided by a regional notification center to every person who contacts the center pursuant to Section 4216.2. The inquiry identification number shall remain valid for not more than 28 calendar days from the date of issuance, and after that date shall require regional notification center revalidation.

(g) "Local agency" means a city, county, city and county, school district, or special district.

(h) "Operator" means any person, corporation, partnership, business trust, public agency, or other entity that owns, operates, or maintains a subsurface installation. For purposes of Section 4216.1, an "operator" does not include an owner of real property where subsurface facilities are exclusively located if they are used exclusively to furnish services on that property and the subsurface facilities are under the operation and control of that owner.

(i) "Qualified person" means a person who completes a training program in accordance with the requirements of Title 8, California Code of Regulations, Section 1509, Injury Prevention Program, that meets the minimum training guidelines and practices of Common Ground Alliance current Best Practices.

(j) "Regional notification center" means a nonprofit association or other organization of operators of subsurface installations that provides advance warning of excavations or other work close to existing subsurface installations, for the purpose of protecting those installations from damage, removal, relocation, or repair.

(k) "State agency" means every state agency, department, division, bureau, board, or commission.

(l) "Subsurface installation" means any underground pipeline, conduit, duct, wire, or other structure, except nonpressurized sewer lines, nonpressurized storm drains, or other nonpressurized drain lines.

4216.1. Every operator of a subsurface installation, except the Department of Transportation, shall become a member of, participate in, and share in the costs of, a regional notification center. Operators of subsurface installations who are members of, participate in, and share in, the costs of a regional notification center, including, but not limited to, the South Shore Utility Coordinating Council, the Underground Service Alert--Northern California or the Underground Service Alert--Southern California are in compliance with this section and Section 4216.9.

4216.2. (a) (1) Except in an emergency, any person planning to conduct any excavation shall contact the appropriate regional notification center, at least two working days, but not more than 14

calendar days, prior to commencing that excavation, if the excavation will be conducted in an area that is known, or reasonably should be known, to contain subsurface installations other than the underground facilities owned or operated by the excavator and, if practical, the excavator shall delineate with white paint or other suitable markings the area to be excavated.

(2) When the excavation is proposed within 10 feet of a high priority subsurface installation, the operator of the high priority subsurface installation shall notify the excavator of the existence of the high priority subsurface installation prior to the legal excavation start date and time, as such date and time are authorized pursuant to paragraph (1) of subdivision (a) of Section 4216.2. The excavator and operator or its representative shall conduct an onsite meeting at a mutually-agreed-on time to determine actions or activities required to verify the location of the high priority subsurface installations prior to start time.

(b) Except in an emergency, every excavator covered by Section 4216.8 planning to conduct an excavation on private property may contact the appropriate regional notification center



if the private property is known, or reasonably should be known, to contain a subsurface installation other than the underground facility owned or operated by the excavator and, if practical, the excavator shall delineate with white paint or other suitable markings the area to be excavated.

(c) The regional notification center shall provide an inquiry identification number to the person who contacts the center pursuant to this section and shall notify any member, if known, who has a subsurface installation in the area of the proposed excavation. An inquiry identification number may be validated for more than 28 days when mutually agreed between the excavator and any member operator so notified that has a subsurface installation in the area of the proposed excavation; and, it may be revalidated by notification to the regional notification center by the excavator prior to the time of its expiration.

(d) A record of all notifications by excavators and operators to the regional notification center shall be maintained for a period of not less than three years. The record shall be available for

inspection by the excavator and any member, or their representative, during normal working hours and according to guidelines for inspection as may be established by the regional notification centers.

(e) As used in this section, the delineation is practical when any of the following conditions exist:

(1) When delineating a prospective excavation site with white paint could not be misleading to those persons using affected streets and highways.

(2) When the delineation could not be misinterpreted as a traffic or pedestrian control.

(3) Where an excavator can determine the exact location of an excavation prior to the time an area has been field marked pursuant to Section 4216.3.

(4) Where delineation could not be construed as duplicative.

(f) Where an excavator makes a determination that it is not practical to delineate the area to be excavated, the excavator shall contact the regional notification center to advise the operators that the excavator shall identify the area to be excavated in another manner sufficient to enable the operator to determine the area of the

excavation to be field marked pursuant to Section 4216.3.

4216.3. (a) (1) Any operator of a subsurface installation who receives timely notification of any proposed excavation work in accordance with Section 4216.2 shall, within two working days of that notification, excluding weekends and holidays, or before the start of the excavation work, whichever is later, or at a later time mutually agreeable to the operator and the excavator, locate and field mark the approximate location and, if known, the number of subsurface installations that may be affected by the excavation to the extent and degree of accuracy that the information is available either in the records of the operator or as determined through the use of standard locating techniques other than excavating, otherwise advise the person who contacted the center of the location of the operator's subsurface installations that may be affected by the excavation, or advise the person that the operator does not operate any subsurface installations that would be affected by the proposed excavation.

(2) Only a qualified person shall perform subsurface installation

locating activities.

(3) A qualified person performing subsurface installation locating activities on behalf of a subsurface installation operator shall use a minimum of a single-frequency utility locating device and shall have access to alternative sources for verification, if necessary.

(4) Operators of high priority subsurface installations shall maintain and preserve all plans and records for its subsurface installations.

(b) Every operator of a subsurface installation who field marks the location of a subsurface installation shall make a reasonable effort to make field markings in conformance with the uniform color code of the American Public Works Association.

(c) If, at any time during an excavation for which there is a valid inquiry identification number, an operator's field markings are no longer reasonably visible, the excavator shall contact the appropriate regional notification center. The regional notification center shall contact any member, if known, who has a subsurface installation in the area of the excavation. Upon receiving timely

notification or renotification pursuant to this subdivision, the operator shall re-locate and re-mark, within two working days, those subsurface installations that may be affected by the excavation to the extent necessary, in conformance with this section.

(d) The excavator shall notify the appropriate regional notification center of the failure of an operator to comply with this section. The notification shall include the inquiry identification number issued by the regional notification center. A record of all notifications received pursuant to this subdivision shall be maintained by the regional notification center for a period of not less than three years. The record shall be available for inspection pursuant to subdivision (d) of Section 4216.2.

4216.4. (a) When the excavation is within the approximate location of subsurface installation, the excavator shall determine the exact location of subsurface installations in conflict with the excavation by excavating with hand tools within the area of the approximate location of subsurface installations as provided by the operators in accordance with Section

4216.3 before using any power-operated or power-driven excavating or boring equipment within the approximate location of the subsurface installation, except that power-operated or power-driven excavating or boring equipment may be used for the removal of any existing pavement if there are no subsurface installations contained in the pavement. If documented notice of the intent to use vacuum excavation devices, or power-operated or power-driven excavating or boring equipment, has been provided to the subsurface installation operator or operators and it is mutually agreeable with the operator or operators and the excavator, the excavator may utilize vacuum excavation devices, or power-operated or power-driven excavating or boring equipment within the approximate location of a subsurface installation and to any depth.

(b) If the exact location of the subsurface installation cannot be determined by hand excavating in accordance with subdivision (a), the excavator shall request the operator to provide additional information to the excavator, to the extent that information is available to the operator, to enable the excavator to



determine the exact location of the installation. The regional notification center shall provide the excavator with the contact phone number of the subsurface installation operator.

(c) An excavator discovering or causing damage to a subsurface installation, including all breaks, leaks, nicks, dents, gouges, grooves, or other damage to subsurface installation lines, conduits, coatings, or cathodic protection, shall immediately notify the subsurface installation operator. The excavator may contact the regional notification center to obtain the contact information of the subsurface installation operator. If high priority subsurface installations are damaged and the operator cannot be contacted, the excavator shall call 911 emergency services.

4216.5. The requirements of this article apply to state agencies and to local agencies which own or operate subsurface installations, except as otherwise provided in Section 4216.1. A local agency which is required to provide the services described in Section 4216.3 may charge a fee in an amount sufficient to cover the cost of providing that service.



4216.6. (a) (1) Any operator or excavator who negligently violates this article is subject to a civil penalty in an amount not to exceed ten thousand dollars (\$10,000).

(2) Any operator or excavator who knowingly and willfully violates any of the provisions of this article is subject to a civil penalty in an amount not to exceed fifty thousand dollars (\$50,000).

(3) Except as otherwise specifically provided in this article, this section is not intended to affect any civil remedies otherwise provided by law for personal injury or for property damage, including any damage to subsurface installations, nor is this section intended to create any new civil remedies for those injuries or that damage.

(4) This article shall not be construed to limit any other provision of law granting governmental immunity to state or local agencies or to impose any liability or duty of care not otherwise imposed by law upon any state or local agency.

(b) An action may be brought by the Attorney General, the district attorney, or the local or state agency which

issued the permit to excavate, for the enforcement of the civil penalty pursuant to this section. If penalties are collected as a result of a civil suit brought by a state or local agency for collection of those civil penalties, the penalties imposed shall be paid to the general fund of the agency. If more than one agency is involved in enforcement, the penalties imposed shall be apportioned among them by the court in a manner that will fairly offset the relative costs incurred by the state or local agencies, or both, in collecting these fees.

(c) Statewide information provided by operators and excavators regarding facility events shall be compiled and made available in an annual report by regional notification centers and posted on the Internet Web sites of the regional notification centers.

(d) For purposes of subdivision (c), the following terms have the following meanings:

(1) "Facility event" means the occurrence of excavator downtime, damages, near misses, and violations.

(2) "Statewide information" means information submitted by operators and excavators using the California Regional

Common Ground Alliance's Virtual Private Damage Information Reporting Tool. Supplied data shall comply with the Damage Information Reporting Tool's minimum essential information as listed in the Common Ground Alliance's most recent Best Practices Handbook.

4216.7. (a) If a subsurface installation is damaged by an excavator as a result of failing to comply with Section 4216.2 or 4216.4, or as a result of failing to comply with the operator's requests to protect the subsurface installation as specified by the operator prior to the start of excavation, the excavator shall be liable to the operator of the subsurface installation for resulting damages, costs, and expenses to the extent the damages, costs, and expenses were proximately caused by the excavator's failure to comply.

(b) If the operator of a subsurface installation has failed to comply with the regional notification center system requirements of Section 4216.1, that operator shall forfeit his or her claim for damages to his or her subsurface installation, arising from the excavation, against an excavator who has complied with the requirements of

Section 4216.2 to the extent damages were proximately caused by the operator's failure to comply.

(c) If an operator of a subsurface installation has failed to comply with the provisions of Section 4216.3, has failed to comply with paragraph (2) of subdivision (a) of Section 4216.2, or has failed to comply with subdivision (b) of Section 4216.4, the operator shall be liable to the excavator who has complied with Sections 4216.2 and 4216.4 for damages, costs, and expenses resulting from the operator's failure to comply with these specified requirements to the extent the damages, costs, and expenses were proximately caused by the operator's failure to comply.

(d) Nothing in this section shall be construed to do any of the following:

(1) Affect claims including, but not limited to, third-party claims brought against the excavator or operator by other parties for damages arising from the excavation.

(2) Exempt the excavator or operator from his or her duty to mitigate any damages as required by common or other applicable law.

(3) Exempt the excavator or operator from liability to each other

or third parties based on equitable indemnity or comparative or contributory negligence.

4216.8. This article does not apply to any of the following persons:

(a) An owner of real property who contracts for an excavation project on the property, not requiring a permit issued by a state or local agency, with a contractor or subcontractor licensed pursuant to Article 5 (commencing with Section 7065) of Chapter 9 of Division 3 of the Business and Professions Code.

(b) An owner of residential real property, not engaged as a contractor or subcontractor licensed pursuant to Article 5 (commencing with Section 7065) of Chapter 9 of Division 3 of the Business and Professions Code, who as part of improving his or her principal residence or appurtenances thereto is performing or having performed excavation work not requiring a permit issued by a state or local agency.

(c) Any person or private entity that leases or rents power operated or power-driven excavating or boring equipment, regardless of whether an equipment operator is provided for that piece of equipment or not, to a contractor or subcontractor licensed pursuant

to Article 5 (commencing with Section 7065) of Chapter 9 of Division 3 of the Business and Professions Code, if the signed rental agreement between the person or private entity and the contractor or subcontractor contains the following provision:

"It is the sole responsibility of the lessee or renter to follow the requirements of the regional notification center law pursuant to Article 2 (commencing with Section 4216) of Chapter 3.1 of Division 5 of Title 1 of the Government Code. By signing this contract, the lessee or renter accepts all liabilities and responsibilities contained in the regional notification center law."

4216.9. (a) No permit to excavate issued by any local agency, as defined in Section 4216, or any state agency, shall be valid unless the applicant has been provided an initial inquiry identification number by a regional notification center pursuant to Section 4216.2. For purposes of this section, "state agency" means every state agency, department, division, bureau, board, or commission, including the Department of Transportation.

(b) This article does not exempt any person or corporation from Sections 7951, 7952, and 7953 of the Public Utilities Code.



CalOSHA Title 8

Construction Safety Orders

Chapter 4, Subchapter 4, Article 6,

Section 1541



§1541. General Requirements.

(a) Surface encumbrances. All surface encumbrances that are located so as to create a hazard to employees shall be removed or supported, as necessary, to safeguard employees.

(b) Subsurface installations.

(1) The approximate location of subsurface installations, such as sewer, telephone, fuel, electric, water lines, or any other subsurface installations that reasonably may be expected to be encountered during excavation work, shall be determined by the excavator prior to opening an excavation.

(A) Excavation shall not commence until:

1. The excavation area has been marked as specified in Government Code Section 4216.2 by the excavator; and

2. The excavator has received a positive response from all known owner/operators of subsurface installations within the boundaries of



the proposed project; those responses confirm that the owner/operators have located their installations, and those responses either advise the excavator of those locations or advise the excavator that the owner/operator does not operate a subsurface installation that would be affected by the proposed excavation.

(B) When the excavation is proposed within 10 feet of a high priority subsurface installation, the excavator shall be notified by the facility owner/operator of the existence of the high priority subsurface installation before the legal excavation start date and time in accordance with Government Code Section 4216.2(a), and an onsite meeting involving the excavator and the subsurface installation owner / operator's representative shall be scheduled by the excavator and the owner / operator at a mutually agreed on time to determine the action or activities required to verify the location of such installations. High priority subsurface installations are high pressure natural gas pipelines with normal operating

pressures greater than 415 kPA gauge (60 p.s.i.g.), petroleum pipelines, pressurized sewage pipelines, conductors or cables that have a potential to ground of 60,000 volts or more, or hazardous materials pipelines that are potentially hazardous to employees, or the public, if damaged.

(C) Only qualified persons shall perform subsurface installation locating activities, and all such activities shall be performed in accordance with this section and Government Code Sections 4216 through 4216.9. Persons who complete a training program in accordance with the requirements of Section 1509, Injury and Illness Prevention Program (IIPP), that meets the minimum training guidelines and practices of the Common Ground Alliance (CGA) Best Practices, Version 3.0, published March 2006, or the standards of the National Utility Locating Contractors Association (NULCA), Standard 101: Professional Competence Standards for Locating Technicians, 2001, First Edition, which are



incorporated by reference, shall be deemed qualified for the purpose of this section.

(D) Employees who are involved in the excavation operation and exposed to excavation operation hazards shall be trained in the excavator notification and excavation practices required by this section and Government Code Sections 4216 through 4216.9.

(2) All Regional Notification Centers as defined by Government Code Section 4216(j) in the area involved and all known owners of subsurface facilities in the area who are not members of a Notification Center shall be advised of the proposed work at least 2 working days prior to the start of any digging or excavation work. EXCEPTION: Repair work to subsurface facilities done in response to an emergency as defined in Government Code Section 4216(d).

(3) When excavation or boring operations approach the approximate location of subsurface installations, the exact location of the installations

shall be determined by safe and acceptable means that will prevent damage to the subsurface installation, as provided by Government Code Section 4216.4.

(4) While the excavation is open, subsurface installations shall be protected, supported, or removed as necessary to safeguard employees.

(5) An excavator discovering or causing damages to a subsurface installation shall immediately notify the facility owner/operator or contact the Regional Notification Center to obtain subsurface installation operator contact information immediately after which the excavator shall notify the facility operator. All breaks, leaks, nicks, dents, gouges, grooves, or other damages to an installation's lines, conduits, coatings or cathodic protection shall be reported to the subsurface installation operator. If damage to a high priority subsurface installation results in the escape of any flammable, toxic, or corrosive gas or liquid or endangers life, health or property, the excavator

responsible shall immediately notify 911, or if 911 is unavailable, the appropriate emergency response personnel having jurisdiction. The facility owner/operator shall also be contacted.

Note: The terms excavator and operator as used in Section 1541(b) shall be as defined in Government Code Section 4216(c) and (h) respectively. The term "owner / operator" means an operator as the term "operator" is defined in Government Code Section 4216(h).

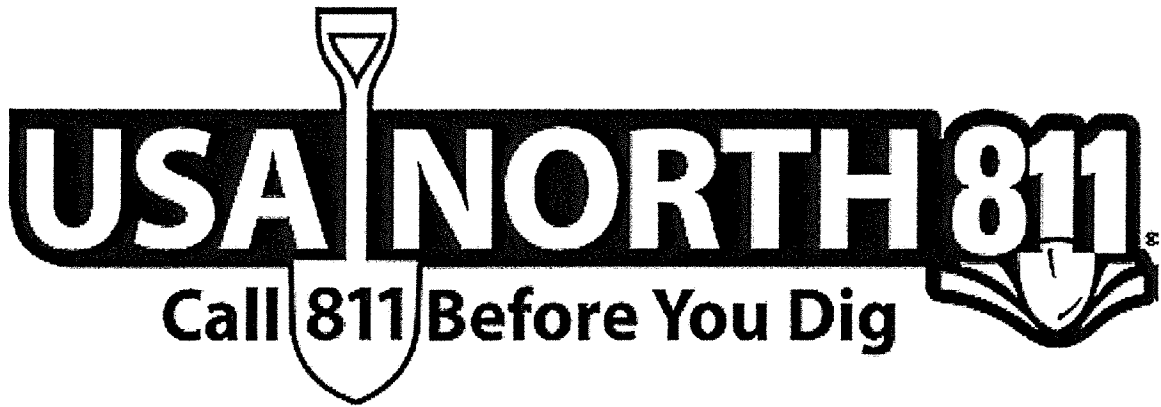

Excavator Handbook



Table of Contents

- **USA North 811 Overview - Page 3**
- **General Information – Page 4**
- **5 Steps to a SAFE Excavation - Page 7**
- **No Response Info – Page 9**
- **Damage/Exposed Info – Page 11**
- **Emergency Notification Info – Page 12**
- **Excerpt from California Contractors License Law & Reference Book, Section IV Chapter 8 – Page 13**
- **CGA Best Practices Appendix B - Marking Guidelines – Page 23**

USA NORTH 811 OVERVIEW

USA North 811 provides a free and effective Damage Prevention Service that protects our citizens, our communities, our environment, our essential public services, and our underground facilities in Central / Northern California and all of Nevada. USA North 811 began operation in May of 1975 and incorporated as a Non-Profit Mutual Benefit Corporation in 1986. Our purpose is to receive planned excavation reports that will begin within the next 14 calendar days from homeowners, excavators or professional contractors and transmit those planned excavation reports to all participating members of USA North 811 who may have facilities at that excavation site. Our members will 1) mark or stake the horizontal path of their facility, 2) provide information about the location of their facility, or 3) advise the excavator of clearance, for facilities that they own, operate or maintain.

Calling hours are from 6 a.m. to 7 p.m. Monday thru Friday except weekends and holidays.



Be knowledgeable of all Federal, State, County, City or Local Requirements:

- Construction Code
- Contractor License Code
- Safety Code
- Franchise Code
- OSHA
- Federal, State, County, City or Local Ordinances
- Others that apply

General Excavation Information:

- Prior to starting an excavation, examine the excavation site for physical evidence (manholes, valve covers, water meters, fire hydrants, sewer cleanouts, storm drains, vaults, utility maintenance boxes, pole risers, etc) that would indicate the existence of underground facilities. Always excavate, as cautiously and prudently as possible.
- USA North 811 accepts calls for excavation work on public or private property, on Military Bases, on Indigenous People's Reservations and even on waterways within our coverage area.
- Our members will mark or stake the horizontal path, provide information about the location, or provide clearance to the excavator for facilities

that they own, operate or maintain. Excavators should be aware there could be other facilities of the same type at the excavation site owned by the property owner or another company who is not a member of USA North.

- Limit your excavation location description to a site that can be completed within a 28 calendar day period from the date of your call to USA North 811 in California or Nevada and so that our members can reasonably locate within 2 working days.
- USA North 811 limits excavation work to areas no longer in length than 1½ miles in a metropolitan area and 3 miles in a rural area.
- Dividing larger excavation areas into smaller manageable sites helps our members respond to your excavation site more promptly.
- As work in one excavation site nears completion, call in your next excavation site to USA North 811 and continue this process until your entire excavation area is complete.
- When working on private property the excavator should determine what facilities belong to the property owner, (water, well, sewer, septic tanks, gas, propane lines, electrical, etc.) and what easement(s) may exist on the property, if any. In general, responsibility of underground facilities transfers to the property owner behind the curb, behind

the sidewalk, clean out, at the meter or point of demarcation. USA North 811 notifies only its utility members of your excavation work. For your safety you should notify any non-member directly.



Five Steps to a Safe Excavation:

1. Survey and Mark: Survey your proposed excavation site. Make a list of affected operators of underground facilities (utility operators) at your job site, their needs and requirements. Mark the excavation site on paved surfaces with white spray chalk, water base, UV paint, or equivalent less permanent type marking; use white flags, stakes, whiskers, etc. on unpaved surfaces, (Homeowners can use flour).

2. Call 811 Before You Dig: Call USA North 811 2 working days to 14 calendar days before you dig. Only operators who are members of the USA North 811 program will be notified. Compare your list of affected operators determined in Step 1, with the list of operators notified by USA North 811. For your safety contact any operator at your job site that is not a member of USA North 811. USA North 811 accepts design inquiry requests through its internet application only. For more information visit our website www.usanorth811.org

3. Wait the Required Time: The legal 2 working days to 14 calendar days notice allows USA North 811 members to examine their underground facility records and respond to you.



Excavators are required by law to wait until all operator(s) of subsurface installations have provided a positive response to their excavation site. The positive response includes operator's marking, or staking the horizontal path of their facility with the appropriate color code, providing information about the location of their facility, or advising the excavator of clearance. Depending on our member's workload, they may contact you to try to negotiate a new start time for your excavation.

4. Respect the Marks: Preserve facility marks for the duration of the job. If any of the operator markings are not reasonably visible, you must call USA North 811 and request re-marking by the affected operator(s). A re-mark request requires a 2 working day notice. When you request an operator(s) to re-mark their facilities, you will be asked if your excavation site is still outlined in white, so the USA North 811 members can respond to your request.

Note: A USA North 811 ticket is active for 28 calendar days in California and Nevada from the date of its issuance. You must have an active USA North 811 ticket for the entire duration of your excavation.



5. Dig With Care: Hand excavate within 24" of the outside diameter of the facility. Facilities that are in conflict with your excavation are to be located with hand tools and protected before power equipment is used. Notify the affected operator(s) of any contact, scrape, dent, nick or damage to their facility.

No Response Follow-Up:

This process starts when the excavator notifies USA North 811 that:

- A 2 working day; to 14 calendar day (legal) notice and,
- The start date/time has passed and,
- A member(s) failed to respond to the excavation site by the legal start date & time of the ticket.

When a member successfully negotiates a new start date/time with an excavator, the negotiated start date/time becomes the legal start date/time for that excavation notice.

Once the start date/time has passed, the excavator should determine if all USA North 811 members have responded. The members will: mark or stake the horizontal path of their facilities, provide information about the location of their



facilities, or advise the excavator of clearance. If the excavator determines that a member(s) of USA North 811 has failed to respond in one of these manners the following steps are to be taken.

1) First No Response Follow-up: Call USA North 811 after the original or agreed upon legal start date/time, that the work was to begin, and request USA North 811 to send a “First No Response Follow-up” to the member(s) (name the particular member(s)) that failed to respond to your notice. Request the member(s) to call and respond ASAP or call and provide clearance.

2) Second No Response Follow-up: Wait at least an hour or more, from your last call, to provide our member(s) an opportunity to call and respond to your first request. After this time has passed and the member(s) still has not contacted you, call and request USA North 811 to send a “Second No Response Follow-up” to the member(s) (name the particular member(s)) that has failed to respond to your notice. Request the member(s) to call and respond ASAP or call and provide clearance.

3) Third No Response Follow-up: Wait at least an hour or more, from your last call, to provide our member(s) an opportunity to call and respond to your second request. After this time has passed and the member(s) still has not

contacted you, call and request USA North 811, to send a “Third No Response Follow-up” to the member(s) (name the particular member(s)) that has failed to respond to your notice. Request the member(s) to call and respond ASAP or call and provide clearance. Note; the Center will attempt to make a call to the member(s) terminal involved and ask the member(s) to respond ASAP once the Third No Response Follow-up message has been transmitted.

Warning: There may be unidentified underground facilities at your job site. The excavator should review the job site for physical evidence of facilities not located, i.e. manholes, valve covers, water meters, sewer cleanouts, vaults, storm drains, fire hydrant, utility maintenance boxes, pole risers, or other facility indicators such as pavement patches etc.

Damage / Exposed Notification:

- An excavator discovering or causing damage to a subsurface installation shall notify the operator of the installation and USA North 811.
- USA North 811 accepts damage / exposed notices from the excavator and transmits the notice to our members in the area of the damage. USA North 811 will also provide the excavator with the emergency telephone



number for the member whose facility was damaged.

Emergency Notification:

- If the damage results in the escape of any flammable, toxic or corrosive gas or liquid or endangers life, health or property, the excavator responsible immediately notifies 911 and the facility owner/operator.

The excavator takes reasonable measures to protect themselves and those in immediate danger, public, property and the environment until the facility owner / operator or emergency responders have arrived and completed their assessment.

Excerpt from:

**California Contractors License Law &
Reference Book**

SECTION IV.

**CONSTRUCTION STANDARDS AND
SAFETY REGULATIONS**

Chapter 8.

**Regional Notification Centers: Underground
Service Alert**

What is a Regional Notification Center?

A regional notification center is an association of owners and operators of subsurface installations (water, gas, electric, telephone, sewer, oil lines, etc.). Damage to underground structures may result in the disruption of essential public services and pose a threat to workers, the public, and environmental safety. The purpose of the center is to provide a single telephone number that excavators can use to give the center's members advance notification of their intent to excavate.



The operators of the underground installations are then responsible for providing information about the locations of the facility, or marking or staking the approximate location of their facility, or advising the excavator of clearance. Operators are only responsible for facilities they own; operators are not responsible for facilities they do not own.

Contacting a Regional Notification Center is a Requirement— Not an Option.

California Government Code §§4216-4216.9 require anyone planning to excavate to contact the appropriate regional notification center at least two (2) working days (but not more than 14 calendar days) before beginning to excavate. The center will issue an inquiry identification number to the excavator as confirmation of the call.

NOTE: An excavation permit is not valid without this identification number.

Who Must Comply:

- Any person or entity who plans to disturb the surface of the ground, whether by digging, drilling, boring, etc.

Exempt Persons:

- An owner of private property who contracts with a contractor or subcontractor (contractor / subcontractor must be state-licensed) for an excavation project that does not require an excavation permit;
- An owner of private property (who is not a licensed contractor or subcontractor) who, as a part of improving his or her or subcontractor) who, as a part of improving his or her principal residence, does work which does not require an excavation permit.
- Regardless of whether an equipment operator is provided for that piece of equipment, any person or private entity that leases or rents owner-operated or power-driven excavating or boring equipment to a contractor or subcontractor licensed pursuant to the Contractors State

License Law if the signed rental agreement between the person or private entity and the contractor or subcontractor contains the following provision: “It is the sole responsibility of the lessee or renter to follow the requirements of the regional notification center law pursuant to Article 2 (commencing with Section 4216) of Chapter 3.1 of Division 5 of Title 1 of the Government Code. By signing this contract, the lessee or renter accepts all liabilities and responsibilities contained in the regional notification center law.”

Steps Required for Compliance:

- Every contractor or subcontractor excavating at a job site must have his or her own Underground Service Alert (USA) identification (ticket) number for the excavation work he or she is performing.
- Excluding emergency situations, parties planning excavation activities must contact the appropriate regional notification center not less than two (2) working days, nor more than 14 calendar days, prior to the start of work.

**NOTE: THE REGIONAL NOTIFICATION
CENTER CALL IS FREE: 811 / 800-227-2600.**

- Upon notification, the center will issue an identification (ticket) number. The ticket number will be valid for 28 calendar days. If work is to continue past 28 calendar days, the ticket number must be revalidated by again notifying the center before the ticket number expires.
- At the site, excavators must clearly mark the boundaries of the work area, usually with white paint.
- Within these boundary markings, operators of underground installations must then provide information about their facilities, mark or stake the location of their lines clearly using the appropriate color to show what type of installation is present, or advise of clearance.
- If, during the course of the job, the operator's markings become no longer visible, the excavator must contact the regional center and request the operator to re-mark the lines within two (2) working days.

- Using the operator's markings, an excavator must determine the exact location of underground facilities with hand tools before any power equipment may be used.

Helpful Hints:

- Be prepared to provide the beginning date and time of your excavation.
- Provide your name, company's name, company's mailing address, telephone number where you can be contacted, nature of work (grading, drilling, etc.), who the work is being done for, the name of the foreman, permit name and number, whether you have outlined your excavation in white paint, and a description of your excavation site.
- When giving the description of your excavation site, be sure to give the address or description of where you will be digging (including side of street, which corner of the intersection, footage, and total distances or other tie-in measurements), nearest intersecting street, city, and county.

Penalties:

- Any operator or excavator who **NEGLIGENTLY** violates any portion of Government Code sections 4216–4216.9 is subject to a fine not to exceed \$10,000.
- Any operator or excavator who **KNOWINGLY AND WILLFULLY** violates any portion of Government Code sections 4216–4216.9 is subject to a fine not to exceed \$50,000.
- An excavator also may be subject to third party claims for damages arising from the excavation work.
- Violation of Government Code sections 4216–4216.9 could result in disciplinary action and possible revocation of your contractor license by the Contractors State License Board.

REGIONAL NOTIFICATION CENTERS

Underground Service Alert of Northern California and Nevada: 811 / (800) 227-2600,
www.usasnorth811.org



Serves the following counties in Northern California:

Alameda, Alpine, Amador, Butte, Calaveras, Colusa, Contra Costa, Del Norte, El Dorado, Fresno, Glenn, Humboldt, Kern, Kings, Lake, Lassen, Madera, Marin, Mariposa, Mendocino, Merced, Modoc, Mono, Monterey, Napa, Nevada, Placer, Plumas, Sacramento, San Benito, San Francisco, San Joaquin, San Luis Obispo, San Mateo, Santa Clara, Santa Cruz, Shasta, Sierra, Siskiyou, Solano, Sonoma, Stanislaus, Sutter, Tehama, Trinity, Tulare, Tuolumne, Yolo, and Yuba.

Serves the entire state of Nevada.

Service: Monday–Friday, 6 a.m.–7 p.m., excluding holidays.

Underground Service Alert of Southern
California— 811 / (800) 227-2600,
www.digalert.org

**Serves the following counties in Southern
California:**

Imperial, Inyo, Los Angeles, Orange, Riverside,
San Bernardino, San Diego, Santa Barbara, and
Ventura

Service: Monday–Friday, 6 a.m.–7 p.m., excluding
holidays

Five Steps to a Safe Excavation:

- 1) Survey and mark.
- 2) Call before you dig.
- 3) Wait the required time.
- 4) Respect the marks.
- 5) Dig with care.

Whatever you do, do it safe, but **CALL AT LEAST TWO (2) WORKING DAYS TO FOURTEEN (14) CALENDAR DAYS BEFORE YOU DIG.**

CGA Best Practices - Appendix B

Uniform Color Code & Marking Guidelines



NOTE: These are suggested marking guidelines by the Common Ground Alliance. Remember, California law always trumps the guidelines of the CGA. Always cross reference suggested CGA marking guidelines and information with California excavation law.

Uniform Color Code^{1/}

The following APWA uniform color code (ANSI Z535.1) shall be adopted as the uniform color code for marking excavation sites and underground facilities in conflict with an excavation. This recommendation is not intended to preempt any existing state requirement that specifies other colors.

| | |
|--------|--|
| White | Proposed Excavation |
| Pink | Temporary Survey Markings |
| Red | Electric Power Lines, Cables, Conduit, and Lighting Cables |
| Yellow | Gas, Oil, Steam, Petroleum, or Gaseous Materials |
| Orange | Communication, Alarm or Signal Lines, Cables, or Conduit |
| Blue | Potable Water |
| Purple | Reclaimed Water, Irrigation, and Slurry Lines |
| Green | Sewers and Drain Lines |

References:

- APWA Uniform Color Code
- Existing operating practices from various states' one call centers
- Existing one call laws from various states
- ANSI Standard Z535.1 Safety Color Code

Tolerance Zone^{1/}

The following examples are of tolerance zones for a 1 in. and 12 in. line:

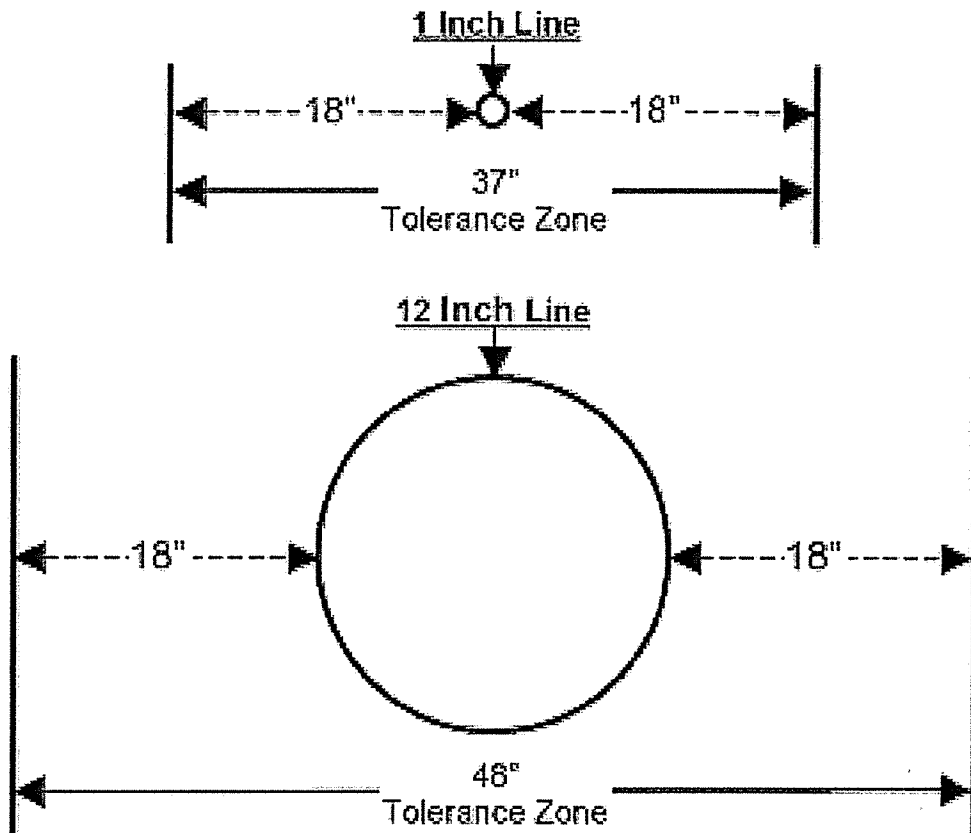

^{1/}TR-2010-01A: Amendment approved by the CGA Board on September 10, 2010

California law requires 24" on either side of the outside diameter of the facility

Guidelines for Excavation Delineation^{1/}

The following marking illustrations are examples of how excavators may choose to mark their area of proposed excavation. The use of white marking products (e.g., paint, flags, stakes, whiskers, or a combination of these) may be used to identify the excavation site.

Single Point Excavations Markings

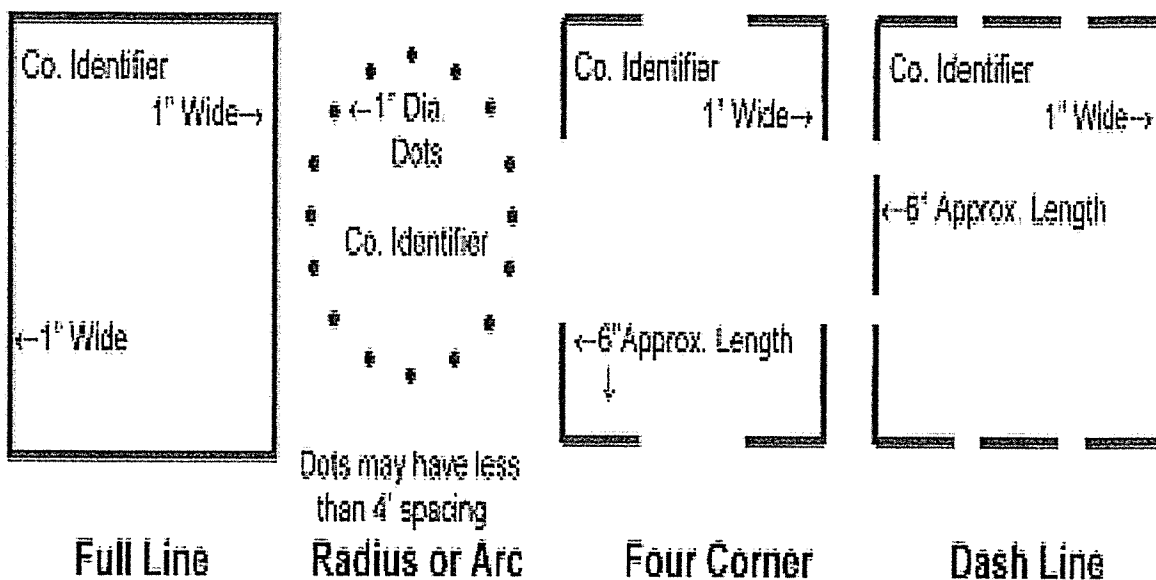

Delineate in white paint the proposed area of excavation using a continuous line, dots marking the radius or arcs, dashes marking the four corners of the project, or dashes outlining the excavation project. Limit the size of each dash to approximately 6 in. to 12 in. long and 1 in. wide with interval spacing approximately 4 ft to 50 ft apart. Reduce the separation of excavation marks

to a length that can reasonably be seen by the operator's locators when the terrain at an excavation site warrants. Dots of approximately 1 in. diameter typically are used to define arcs or radii and may be placed at closer intervals in lieu of dashes.

Single Stake Marking Center Point of Excavation Site

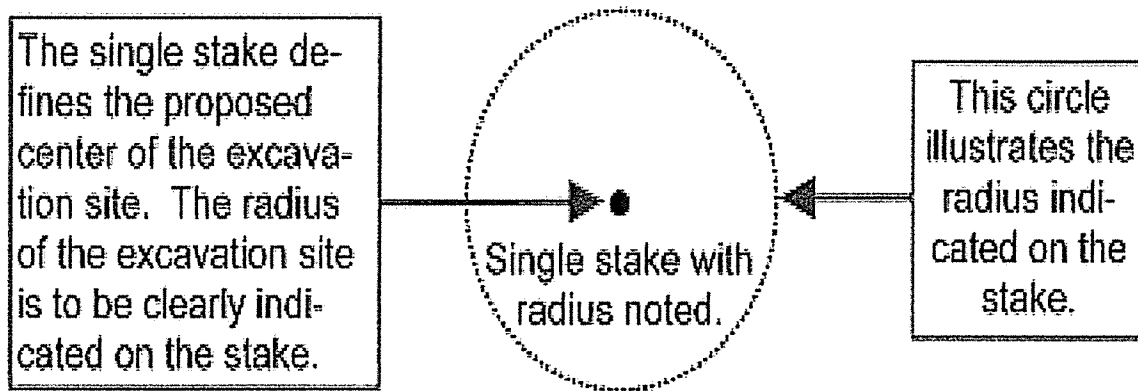

When an excavation site is contained within a 50 ft maximum radius or less, it can be delineated with a single stake that is positioned at the proposed center of the excavation. If the excavator chooses this type of delineation, they must convey that they have delineated the excavation site with a single stake at the center of the excavation and include the radius of the site in the notification to the one call center. This single stake is white in color and displays the excavator's company identifier (name,

abbreviations, or initials) and the radius of the excavation site in black letters on the stake or with a notice attached to the stake.

Trenching, Boring, or Other Continuous-Type Excavations

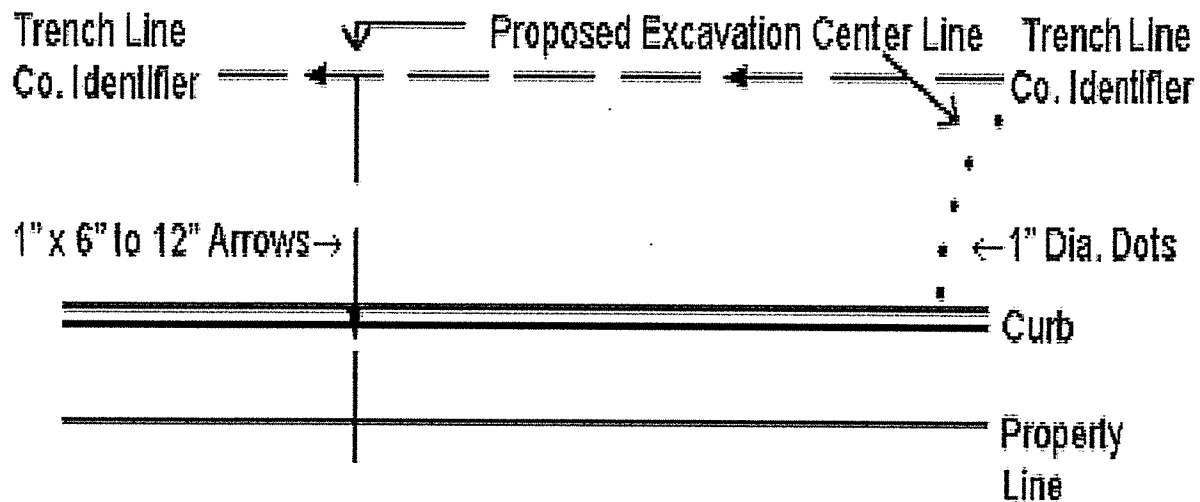

Continuous Excavation Marking

Mark in white paint the proposed centerline of planned excavation using 6 in. to 12 in. x 1 in. arrows approximately 4 ft to 50 ft apart to show direction of excavation. Reduce the separation of excavation marks to a length that can reasonably be seen by the operator's locators when the terrain at an excavation site warrants. Mark lateral excavations with occasional arrows showing excavation direction from centerline with marks at curb or property line if crossed. Dots may be used for curves and closer interval marking.

Stake, Flag, or Whisker Excavation Markers

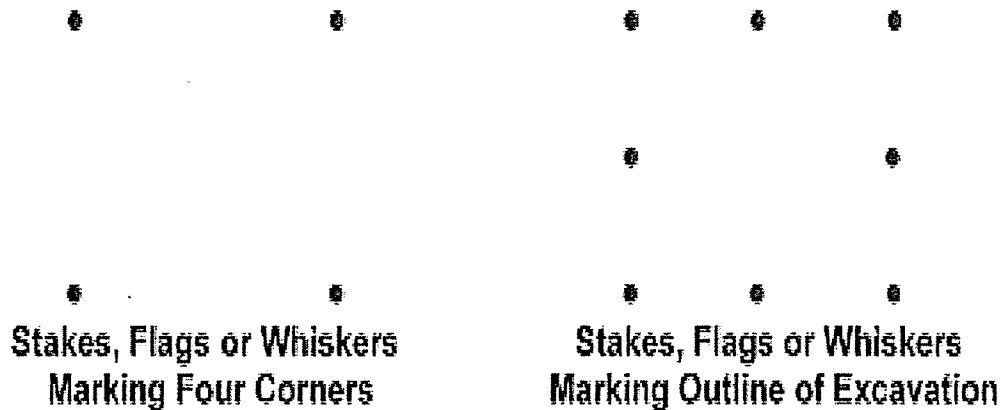

Delineate the proposed area of excavation using stakes, flags, or whiskers instead of spray paint to mark radius or arcs; the four corners of the project; or when outlining the excavation project. Limit the interval spacing to approximately 4 ft to 50 ft. Reduce the separation of excavation marks to a length that can reasonably be seen by the operator's locators when the terrain at an excavation site warrants. Stakes, flags, or whiskers provided to illustrate arcs or radii may be placed at closer intervals to define the arc or radius. Stakes, flags, or whiskers are white in color and display the excavator's company identifier (name, abbreviations, or initials).

^{1/}—TR-2001-05: Amendment approved by the CGA Board on September 24, 2004

Guidelines for Operator Facility Field Delineation^{1/}

Operator markings of facilities include the following:

- The appropriate color for their facility type
- Their company identifier (name, initials, or abbreviation) when other companies are using the same color
- The total number of facilities and the width of each facility
- A description of the facility (HP, FO, STL, etc).

Use paint, flags, stakes, whiskers, or a combination to identify the operator's facility(s) at or near an excavation site.

1. Marks in the appropriate color are approximately 12 in. to 18 in. long and 1 in. wide, spaced approximately 4 ft to 50 ft apart. When marking facilities, the operator considers the type of facility being located, the terrain of the land, the type of excavation being done, and the method required to adequately mark the facilities for the excavator.

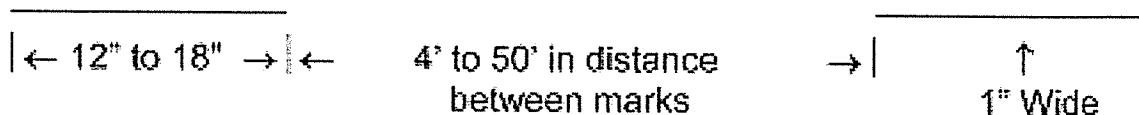

2. The following marking examples illustrate how an operator may choose to mark their subsurface installations:

- a. **Single Facility Marking:** Used to mark a single facility. This can be done in one of two ways—1) placing the marks over the approximate center of the facility:

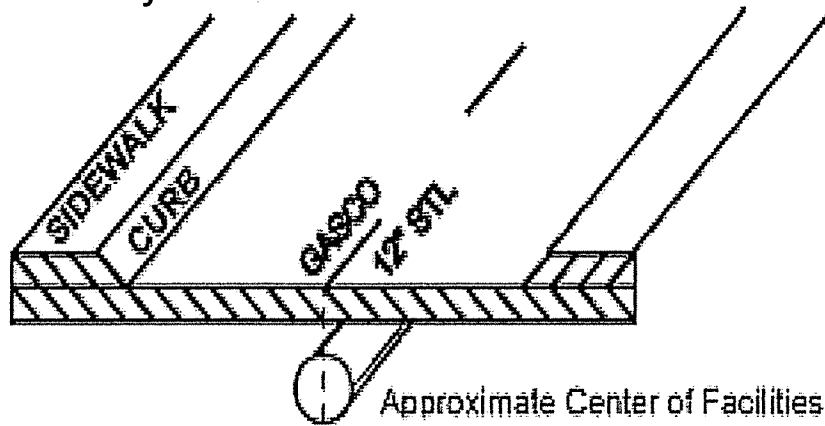

- or 2) placing the marks over the approximate outside edges of the facility with a line connecting the two horizontal lines (in the form of an H) to indicate there is only one facility:

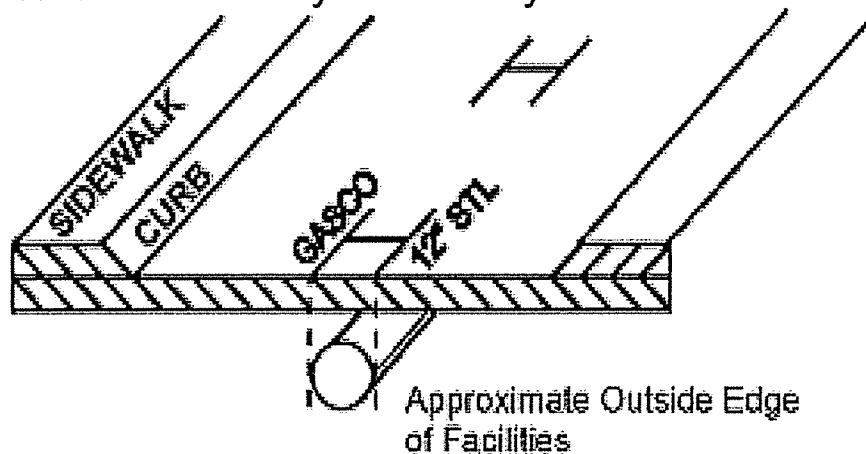

These examples indicate an operator's 12 in. facility. When a facility can be located or toned separately from other facilities of the same type, it is marked as a single facility.²¹

- b. **Multiple Facility Marking:** Used to mark multiple facilities of the same type (e.g., electric), where the

separation does not allow for a separate tone for each facility, but the number and width of the facilities is known. Marks are placed over the approximate center of the facilities and indicate the number and width of the facilities.

Example: four plastic facilities that are 4 in. in diameter (4/4" PLA)

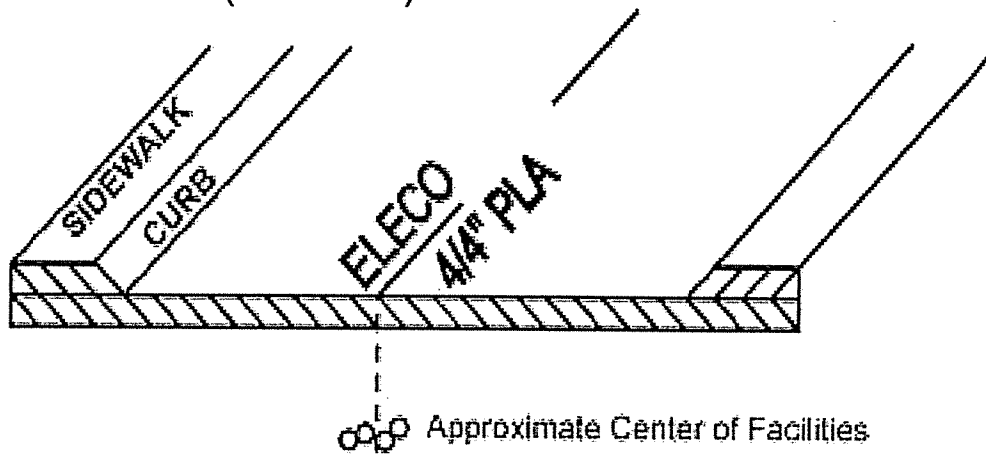

- c. **Conduit Marking:** Used for any locatable facility being carried inside conduits or ducts. The marks indicating the outer extremities denote the actual located edges of the facilities being represented.

Example: four plastic conduits that are 4 in. in diameter (4/4" PLA), and the marks are 16 in. apart, indicating the actual left and right edges of the facilities

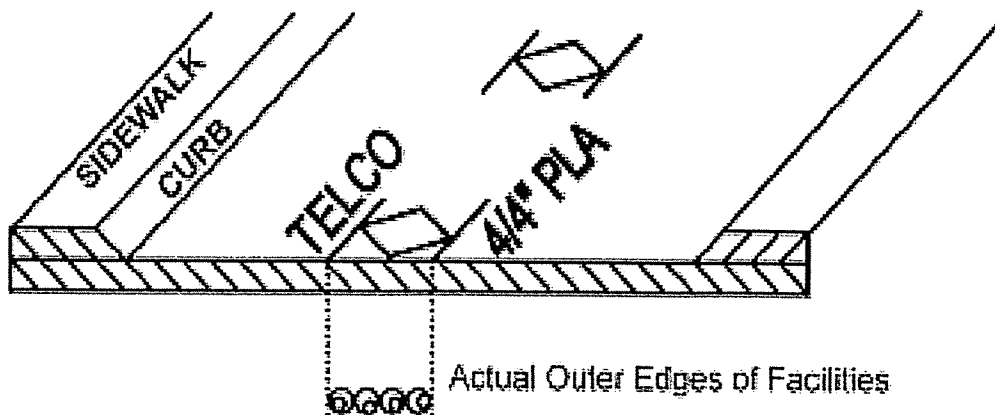

- d. **Corridor Marking:** Used to mark multiple facilities of the same type (e.g., electric), bundled or intertwined in the same trench, where the total number of facilities is not readily known (operator has no record on file for the number of facilities). Marks are placed over the approximate center of the facilities and indicate the width of the corridor. The width of the corridor is the distance between the actual located outside edges of the combined facilities.

Example: a 12 in. corridor (12" CDR)

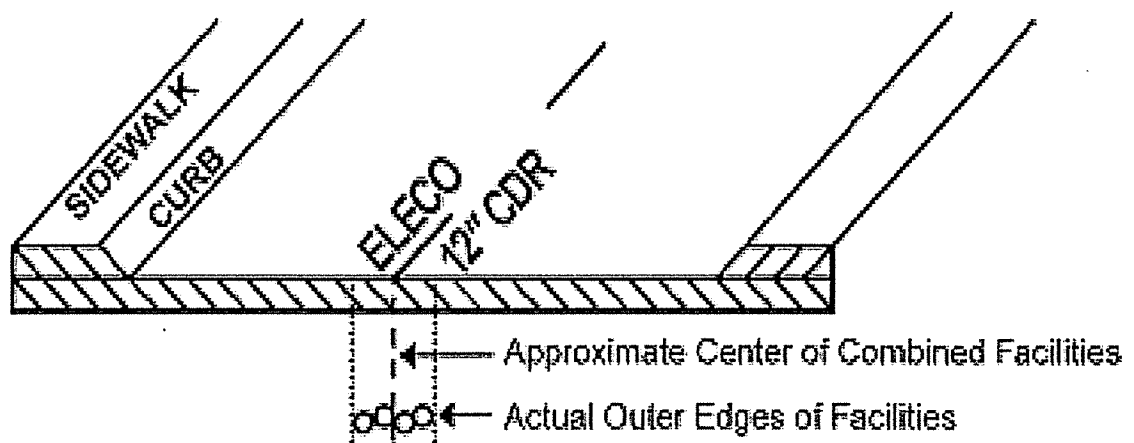

3. Changes in direction and lateral connections are clearly indicated at the point where the change in direction or connection occurs, with an arrow indicating the path of the facility. A radius is indicated with marks describing the arc. When providing offset markings (paint or stakes), show the direction of the facility and distance to the facility from the markings.

Example: radius

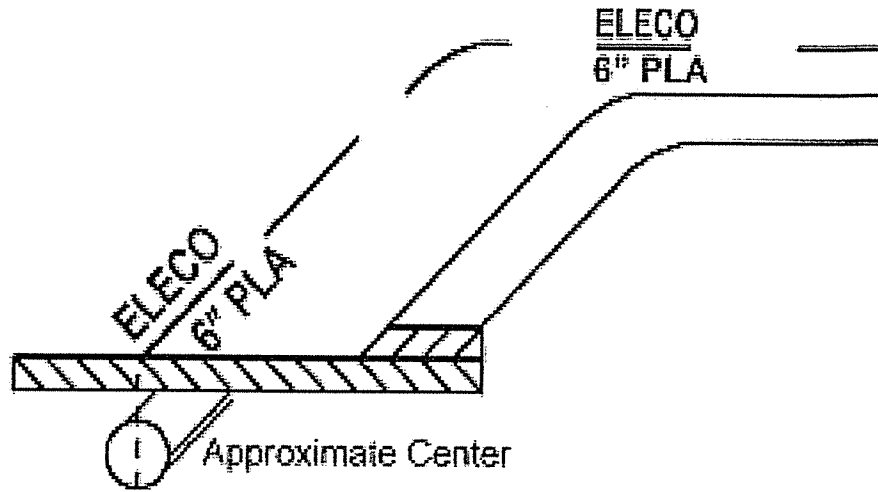

Example: lateral connection

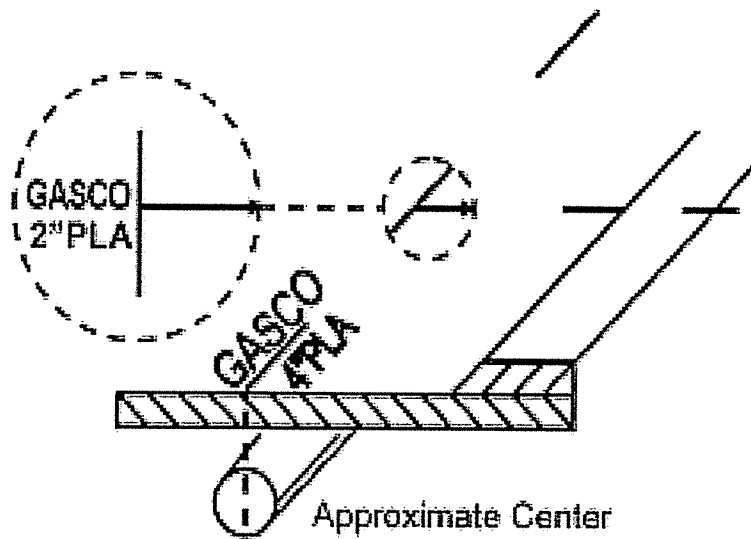

Example: painted offset (off)

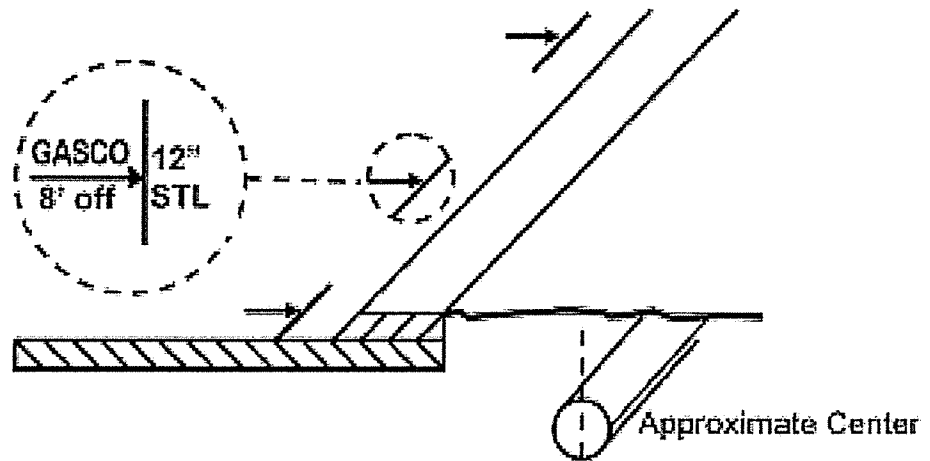

Example: staked offset (off)

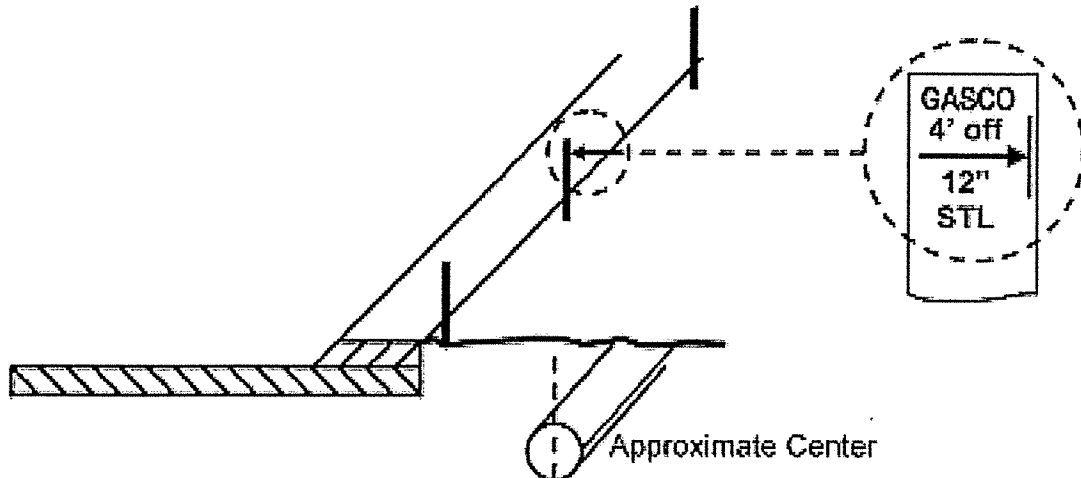

4. An operator's identifier (name, abbreviation, or initials) is placed at the beginning and at the end of the proposed work. In addition, subsequent operators using the same color mark their company identifier at all points where their facility crosses another operator's facility using the same color. Reduce the separation of excavation marks to a length that can reasonably be seen by the operator's locators when the terrain at an excavation site warrants.

Examples:

CITYCO

ELECO

TELCO

5. Information regarding the size and composition of the facility is marked at an appropriate frequency.

Examples: the number of ducts in a multi-duct structure, width of a pipeline, and whether it is steel, plastic, cable, etc.

TELCO

GASCO

WATERCO

9/4" CAB

4" PLA

12" STL

6. Facilities installed in a casing are identified as such.

Examples: 6 in. plastic in 12 in. steel and fiber optic in 4 in. steel

GASCO

TELCO

6" PLA/12" STL

FO (4" STL)

7. Structures such as vaults, inlets, and lift stations that are physically larger than obvious surface indications are marked so as to define the parameters of the structure.

Example:



ELECO Vault

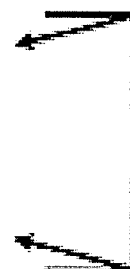
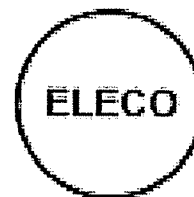
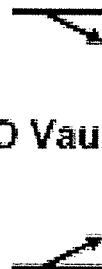

8. Termination points or dead ends are indicated as such.

Example:



9. When there is “No Conflict” with the excavation, complete one or more of the following:

- Operators of a single type of facility (e.g., TELCO) mark the area “NO” followed by the appropriate company identifier in the matching APWA color code for that facility.

Example: NO TELCO

- Operators of multiple facilities mark the area “NO” followed by the appropriate company identifier in the matching APWA color code for that facility with a slash and the abbreviation for the type of facility for which there is “No Conflict.”

Example: NO GASCO/G/D illustrates that GASCO has no gas distribution facilities at this excavation site. The following abbreviations are used when appropriate: /G/D (gas distribution); /G/T (gas transmission); /E/D (electric distribution); /E/T (electric transmission).

- Place a clear plastic (translucent) flag that states “No Conflict” in lettering matching the APWA color code of the facility that is not in conflict. Include on the flag the operator’s

identifier, phone number, a place to write the locate ticket number, and date. Operators of multiple facilities indicate on the flag which facilities are in “No Conflict” with the excavation (see the previous example).

- If it can be determined through maps or records that the proposed excavation is obviously not in conflict with their facility, the locator or operator of the facility may notify the excavator of “No Conflict” by phone, fax, or e-mail, or through the one call center, where electronic positive response is used. Operators of multiple facilities indicate a “No Conflict” for each facility (see the previous examples).
- Place “No Conflict” markings or flags in a location that can be observed by the excavator and/or notify the excavator by phone, fax, or e-mail that there is “No Conflict” with your facilities. When the excavation is delineated by the use of white markings, place “No Conflict” markings or flags in or as near as practicable to the delineated area.

Caution: Allow adequate space for all facility mark-outs.

“No Conflict” indicates that the operator verifying the “No Conflict” has no facilities within the scope of the delineation; or when there is no delineation, there are no facilities within the work area as described on the locate ticket.

Example:

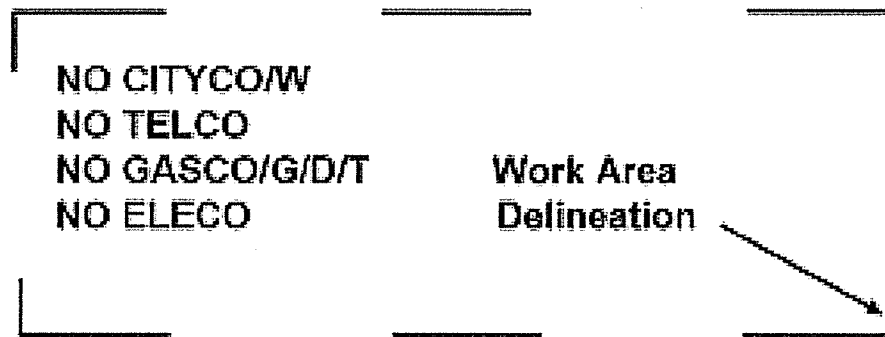

^{1/}TR-2001-05: Amendment approved by the CGA Board on September 24, 2004

^{2/}TR-2010-01B: Amendment approved by the CGA Board on September 10, 2010

Common Abbreviations

Facility Identifier

| | |
|-----|--------------------------|
| CH | Chemical |
| E | Electric |
| FO | Fiber Optic |
| G | Gas |
| LPG | Liquefied Petroleum Gas |
| PP | Petroleum Products |
| RR | Railroad Signal |
| S | Sewer |
| SD | Storm Drain |
| SS | Storm Sewer |
| SL | Street Lighting |
| STM | Steam |
| SP | Slurry System |
| TEL | Telephone |
| TS | Traffic Signal |
| TV | Television |
| W | Water |
| W | Reclaimed Water "Purple" |

Underground Construction Descriptions

| | |
|-----|---|
| C | Conduit |
| CDR | Corridor |
| D | Distribution Facility |
| DB | Direct Buried |
| DE | Dead End |
| JT | Joint Trench |
| HP | High Pressure |
| HH | Hand Hole |
| MH | Manhole |
| PB | Pull Box |
| R | Radius |
| STR | Structure (vaults, junction boxes, inlets, lift stations) |
| T | Transmission Facility |

Infrastructure Material

| | |
|------|-------------------------------------|
| ABS | Acrylonitrile - Butadiene - Styrene |
| ACP | Asbestos Cement Pipe |
| CI | Cast Iron |
| CMC | Cement Mortar Coated |
| CML | Cement Mortar Lined |
| CPP | Corrugated Plastic Pipe |
| CMP | Corrugated Metal Pipe |
| CU | Copper |
| CWD | Creosote Wood Duct |
| HDPE | High Density Polyethylene |
| MTD | Multiple Tile Duct |
| PLA | Plastic (conduit or pipe) |
| RCB | Reinforced Concrete Box |
| RCP | Reinforced Concrete Pipe |
| RF | Reinforced Fiberglass |
| SCCP | Steel Cylinder Concrete Pipe |
| STL | Steel |
| VCP | Vertrified Clay Pipe |

Guide for Abbreviation Use

Follow these guidelines when placing abbreviations in the field:

- Place the Company Identifier at the top or at the left of the abbreviations.
- Place the abbreviations in the following order: Company Identifier / Facility Identifier / Underground Construction Descriptions / Infrastructure Material

Example: TELCO/TEL/FO/PLA indicates that TELCO has a telecommunication fiber optic line in a single plastic conduit. The use of the abbreviation /TEL is not necessary, because the orange marking would indicate that the facility was a communication line; but its use is optional.

- To omit one or more of the abbreviation types, use the order described above but omit the slash and abbreviation that does not apply.

Example: to omit /TEL), the result would be TELCO/FO/PLA.

